

Cougar[®] **DC Truck Vibrators**



Operator's Manual
M3952

Important

MARTIN ENGINEERING HEREBY DISCLAIMS ANY LIABILITY FOR: DAMAGE DUE TO CONTAMINATION OF THE MATERIAL; USER'S FAILURE TO INSPECT, MAINTAIN AND TAKE REASONABLE CARE OF THE EQUIPMENT; INJURIES OR DAMAGE RESULTING FROM USE OR APPLICATION OF THIS PRODUCT CONTRARY TO INSTRUCTIONS AND SPECIFICATIONS CONTAINED HEREIN. MARTIN ENGINEERING'S LIABILITY SHALL BE LIMITED TO REPAIR OR REPLACEMENT OF EQUIPMENT SHOWN TO BE DEFECTIVE.

Observe all safety rules given herein along with owner and Government standards and regulations. Know and understand lockout/tagout procedures as defined by American National Standards Institute (ANSI) z244.1-1982, *American National Standard for Personnel Protection - Lockout/Tagout of Energy Sources - Minimum Safety Requirements* and Occupational Safety and Health Administration (OSHA) Federal Register, Part IV, 29 CFR Part 1910, *Control of Hazardous Energy Source (Lockout/Tagout); Final Rule*.

The following symbols may be used in this manual:



Danger: Immediate hazards that will result in severe personal injury or death.



Warning: Hazards or unsafe practices that could result in personal injury.



Caution: Hazards or unsafe practices that could result in product or property damages.



Important: Instructions that must be followed to ensure proper installation/operation of equipment.



Note: General statements to assist the reader.

Table of Contents

Section	Page
List of Figures	ii
List of Tables	ii
Introduction	1
General	1
References	1
Safety	1
Materials required	1
Before Installing Vibrator	2
Installing Vibrator	3
Steel/aluminum truck box reinforcement	3
Electrical connections	6
Starting Cougar® DC Truck Vibrators	8
Troubleshooting	9
Maintenance	10
Part Numbers	11

List of Figures

Figure	Title	Page
1	Mounting Vibrator on Truck Bed	3
2	Cougar® DC Electric Vibrators Wiring Diagram	6
3	Ground Strap Connections	7
4	Cougar® DC Truck Vibrator Assembly, P/N TDCXX-XXXX-XX-XX	12
5	Eccentric Weight Settings	14

List of Tables

Table	Title	Page
I	Bolt Torque Specifications	5
II	Cougar® DC Truck Vibrator Part Numbers and Quantities.	13

Introduction

General

Cougar® DC Truck Vibrators are equipped with motor-driven rotary eccentric weights that are powered by a DC electric motor and deliver rotary vibration. The motor is attached to the head or case assembly containing the eccentric weights and bearings.

Cougar® DC Truck Vibrators are available in 12V and 24V sizes and are available with permanent mounts.

References

The following documents are referenced in this manual:

- *The National Electrical Code (NEC)*. National Fire Protection Association, 1 Batterymarch Park, P.O. Box 9101, Quincy MA 02269-9101.
- American National Standards Institute (ANSI) z244.1-1982, *American National Standard for Personnel Protection - Lockout/Tagout of Energy Sources - Minimum Safety Requirements*, American National Standards Institute, Inc., 1430 Broadway, New York, NY 10018.
- Federal Register, Volume 54, Number 169, Part IV, 29 CFR Part 1910, *Control of Hazardous Energy Source (Lockout/Tagout); Final Rule*, Department of Labor, Occupational Safety Health Administration (OSHA), 32nd Floor, Room 3244, 230 South Dearborn Street, Chicago, IL 60604.

Safety

All safety rules in the above documents and all owner/employer safety rules must be strictly followed when working with this unit.



Truck box must be supported by a device other than the truck lift system (i.e. truck box prop) during vibrator installation. Failure to do so may result in injury or death.

Materials required

Only standard hand tools are required to install and maintain this equipment.

Before Installing Vibrator

IMPORTANT

The delivery service is responsible for damage occurring in transit. Martin Engineering CANNOT enter claims for damages. Contact your transportation agent for more information.

1. Inspect shipping container for damage. Report damage to delivery service immediately and fill out delivery service's claim form. Keep any damaged goods subject to examination.
2. Remove vibrator from shipping container.
3. If anything is missing or damaged, contact Martin Engineering or a representative.

⚠ CAUTION

Truck box must be supported by a device other than the truck lift system (i.e. truck box prop) during vibrator installation. Failure to do so may result in injury or death.

⚠ WARNING

If equipment will be installed in an enclosed area, gas level or dust content must be tested before using a cutting torch or welding. Using a cutting torch or welding in an area with gas or dust may cause an explosion.

4. If using a cutting torch or welding, test atmosphere for gas level or dust content.
5. Make sure mounting surface is strong and flat, within 1/32 in. (1.2 mm) across vibrator feet. (This will prevent internal stress to vibrator casting when tightening mount bolts.)
6. Make sure mounting surface and vibrator are clean and free of debris.

IMPORTANT

The Cougar® DC Truck Vibrator is NOT guaranteed for continuous duty.

The recommended duty cycle for Cougar® DC Truck Vibrators is a maximum of 45 seconds on-time and a minimum of 90 seconds off-time. Operation in excess of the recommended duty cycle could void the warranty.

Installing Vibrator

⚠ CAUTION

If installation instructions are not followed, structure and vibrator can be damaged. Abusing or handling vibrator carelessly will accelerate wear and shorten bearing life.

⚠ CAUTION

Truck box must be supported by a device other than the truck lift system (i.e. truck box prop) during vibrator installation. Failure to do so may result in injury or death.

Never weld structure with vibrator mounted and wired. Welding may cause damage to motor components and bearings.

Steel/aluminum truck box reinforcement

NOTE

Always mount vibrator where it will not conflict with truck frame or components mounted on frame when box is lowered.

1. For maximum vibrator efficiency, secure vibrator onto the frame rails that run the length of the box. This ensures even distribution of vibration to the entire truck box.
2. This is usually accomplished by positioning a piece of heavy wall channel between the two long frame rails in the front 1/3 of the dump body (refer to Figure 1 or 2).

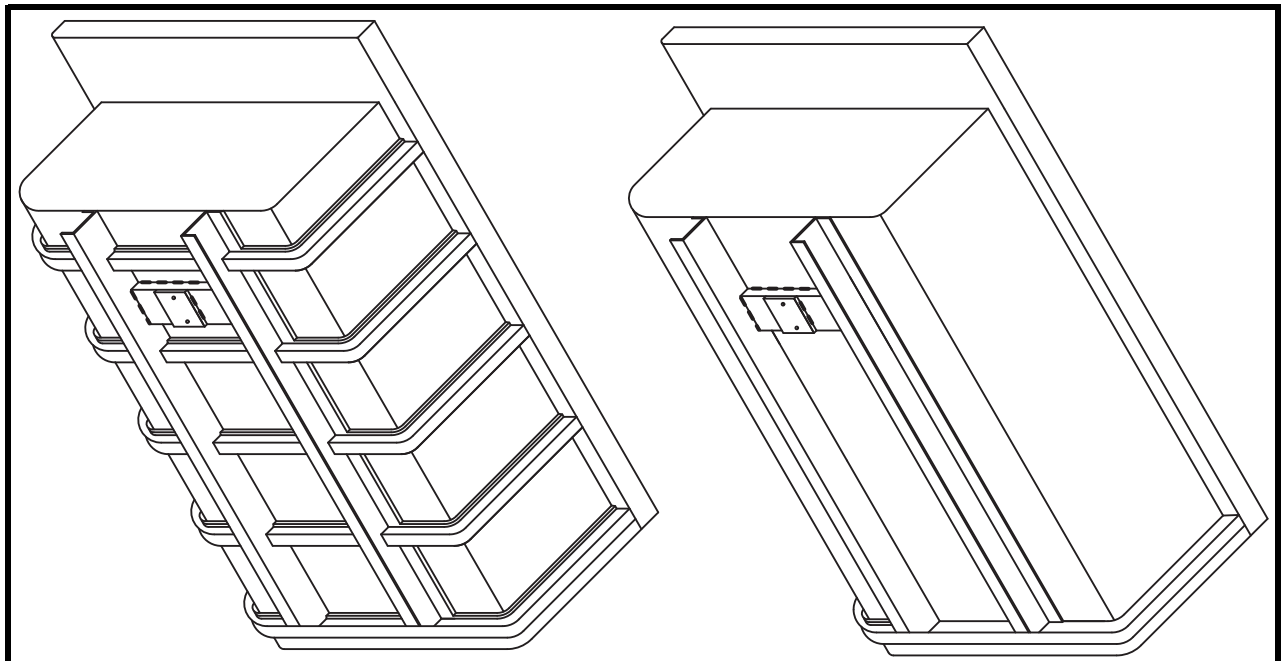

Figure 1. Steel Truck Box Reinforcement and Vibrator Mount

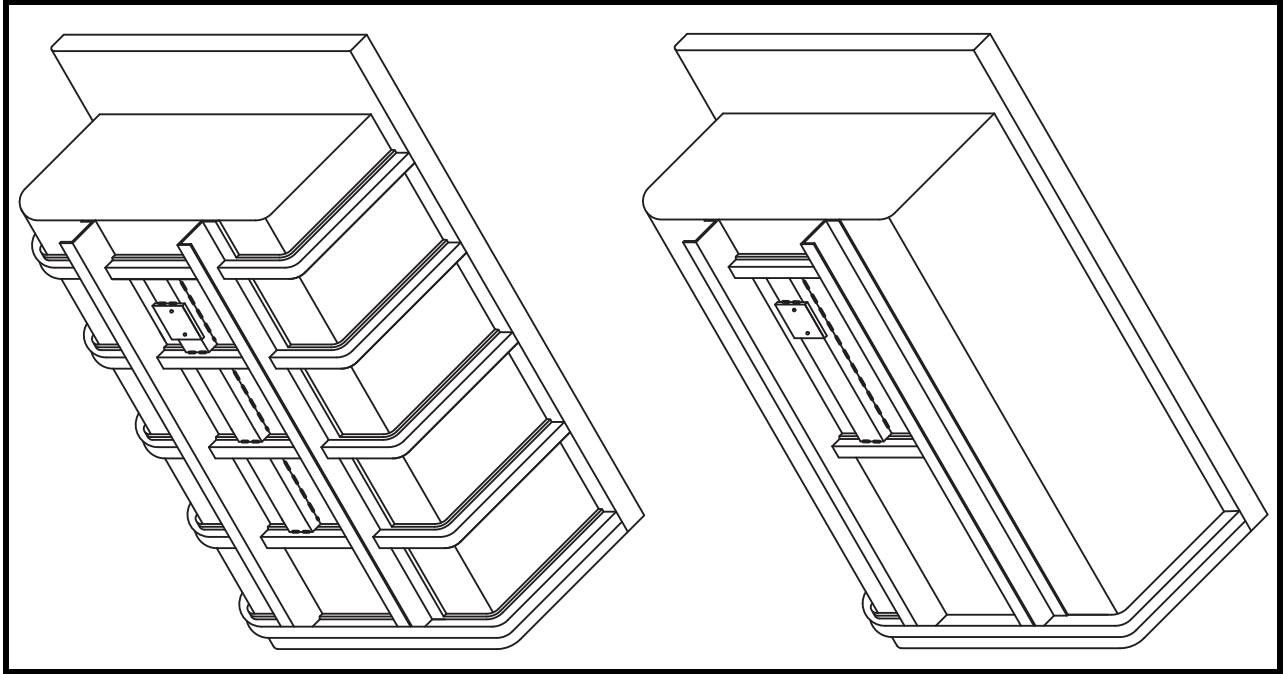

Figure 2. Aluminum Truck Box Reinforcement and Vibrator Mount

3. Cut channel to length and if necessary notch to permit full contact with box and frame members.
4. Position mount plate where vibrator will not interfere with lowering of the truck box.
5. Skip weld mount plate and channel legs to truck box.

▲ CAUTION

Use only new bolts and compression washers to install vibrator. Old fasteners can break and cause damage to vibrator or structure.

Do not use split lock washers to install vibrator onto mount. Damage to vibrator could result.

Make sure mounting surface is flat and free of dirt, grease, paint, and weld slag.

6. Install vibrator onto mounting plate with new compression washers and bolts. The threaded mount supplied with kit may also be used. See Table I for specific size and torque requirements. Use liquid thread fastener to help secure bolts.

Table I. Bolt Torque Specifications

Bolt size	Bolt Torque		Bolt Grade
	ft-lbs	N·m	
5/16 in.	15	20	5
3/8 in.	31	42	5
1/2 in.	75	102	5
5/8 in.	150	203	5
3/4 in.	266	361	5
3/4 in.	376	510	8

▲ WARNING

If vibrator is mounted more than 6 in. (152 mm) above ground, install cable securing vibrator to structure. Without cable, vibrator could fall and cause injury.

7. Secure vibrator to structure by installing safety cable kit, P/N 32271, or equivalent, as follows:
 - a. Weld D-ring onto structure wall above vibrator.
 - b. Make loop to fit around a 3/8" bolt using the cable and cable clamps supplied with kit. Change out a 3/8 -16 x 1-1/4" long bolt to a 3/8 - 16 x 1-1/4 long bolt and a 3/8" flat washer. Tighten securely, then attach to D-ring on structure wall.
 - c. Take up slack within safety restrictions.
 - d. Install four cable clamps (two on each) to secure cable to vibrator handle and D-ring. Torque cable clamps to 15-30 ft-lbs (20-40 N·m).

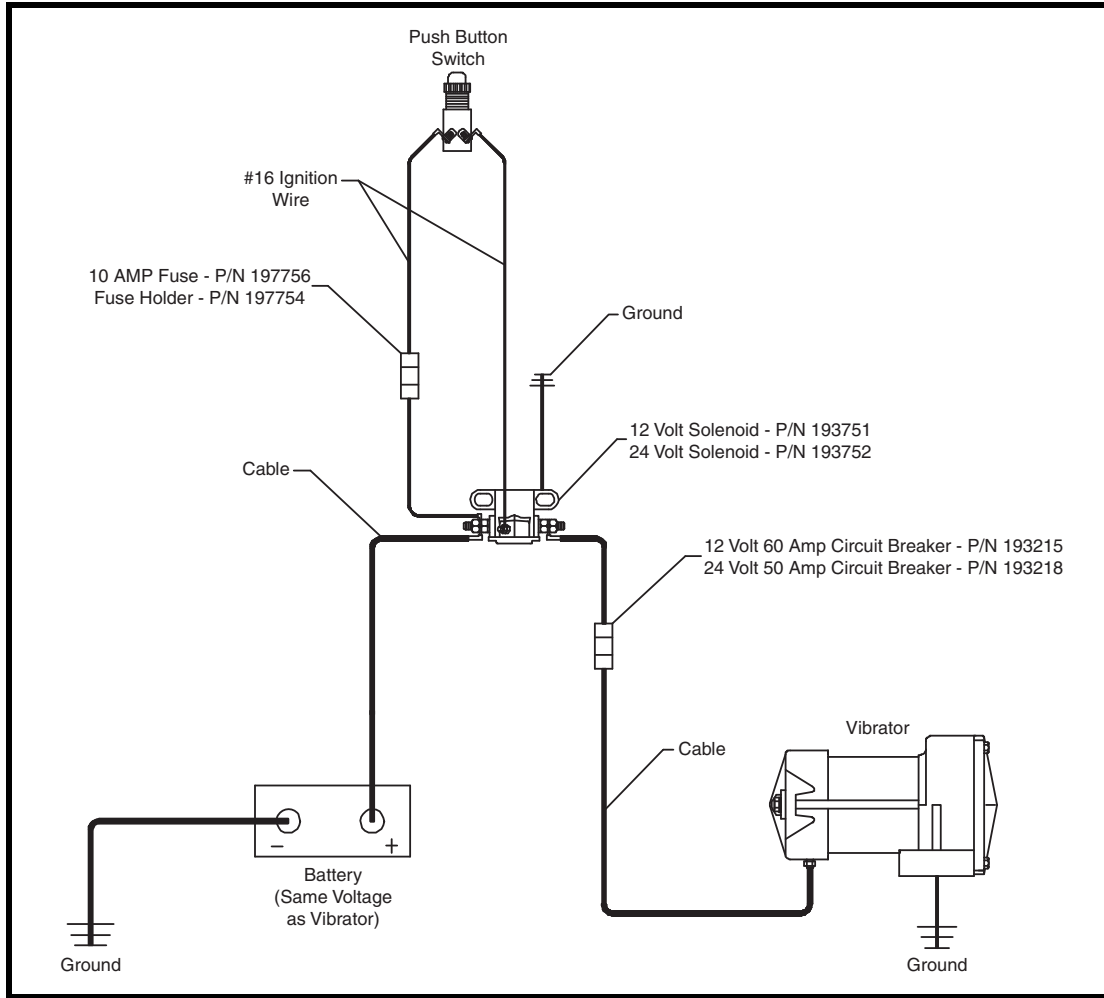

Figure 3. Cougar® DC Electric Vibrators Wiring Diagram without Timer

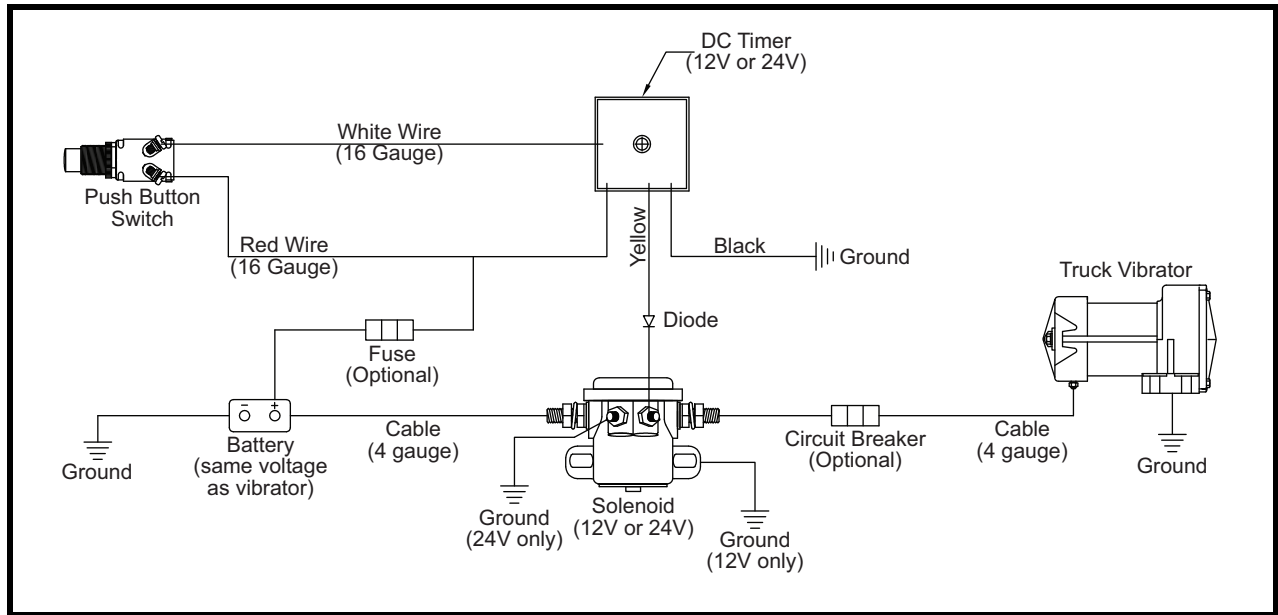

Figure 4. Cougar® DC Electric Vibrators Wiring Diagram with Timer

▲ WARNING

Use DC voltage only. Protect all connections from moisture. Do not turn on energy source to vibrator until all steps of this procedure have been performed.

1. Position the switch on the dashboard of the truck or other location where it will be convenient to operate.
2. Attach solenoid to a grounded surface on the chassis frame, battery box, or a convenient area in the truck's engine compartment. Note: for the 24V solenoid, use one of the two small terminals for ground.

NOTE

If not using a timer (Figure 3) skip to step 7.

3. Mount the timer close to the push button switch.
4. Connect the timer red wire to a positive power source with #16-gauge wire (inline fuse is optional, but recommended).
5. Connect the timer black wire to a grounding source with #16-gauge wire. (Ground source should be separate from solenoid ground source.)
6. Connect the diode assembly to the yellow wire of the timer. The gray line on the diode faces away from the timer. Connect the side of the diode wire assembly to the small terminal on the solenoid with #16 ignition wire.
7. Connect one side of the push button switch to a positive power source with #16-gauge wire (inline fuse is optional, but recommended). If a timer is used, connect the other side of the switch to the white wire of the timer. If no timer is used, connect the wire to the small terminal on the solenoid with #16 ignition wire.
8. Remove 1/2" of insulation from #4 cable. Crimp and solder terminal end to cable.
9. Attach cable to the vibrator.
10. Run the cable down the truck box and around the pivot point in a position where the cable will not be pinched or pulled when the box is raised and lowered. (See Figure 3.)
11. Continue running cable from the pivot point along the frame to the solenoid. Cut the cable to proper length; crimp and solder terminal end and connect to solenoid.
12. Clip or wire tie cable in place along the body and frame.
13. Cut a section of #4 cable long enough to reach from the positive battery terminal to solenoid.
14. Remove 1/2" of cable insulation from each end. Install terminal ends by crimping and soldering.
15. Attach cable to solenoid and route cable to battery.
16. Attach cable to positive battery terminal.
17. Make sure truck box is properly grounded by running a ground strap behind the pivot point and attach to truck frame. This will ensure that the vibrator has the best possible ground. (See Figure 3.) Use #4 wire and ring terminals provided to make a ground strap.
18. Test run vibrator by briefly pushing the "Push Button" switch.
19. Re-torque the vibrator mounting bolts.

NOTE

For positive ground systems, make connections to the negative battery terminal.

NOTE

It is necessary to connect a ground strap from the box to the truck frame using #4 flexible cable. (See Figure 5.)

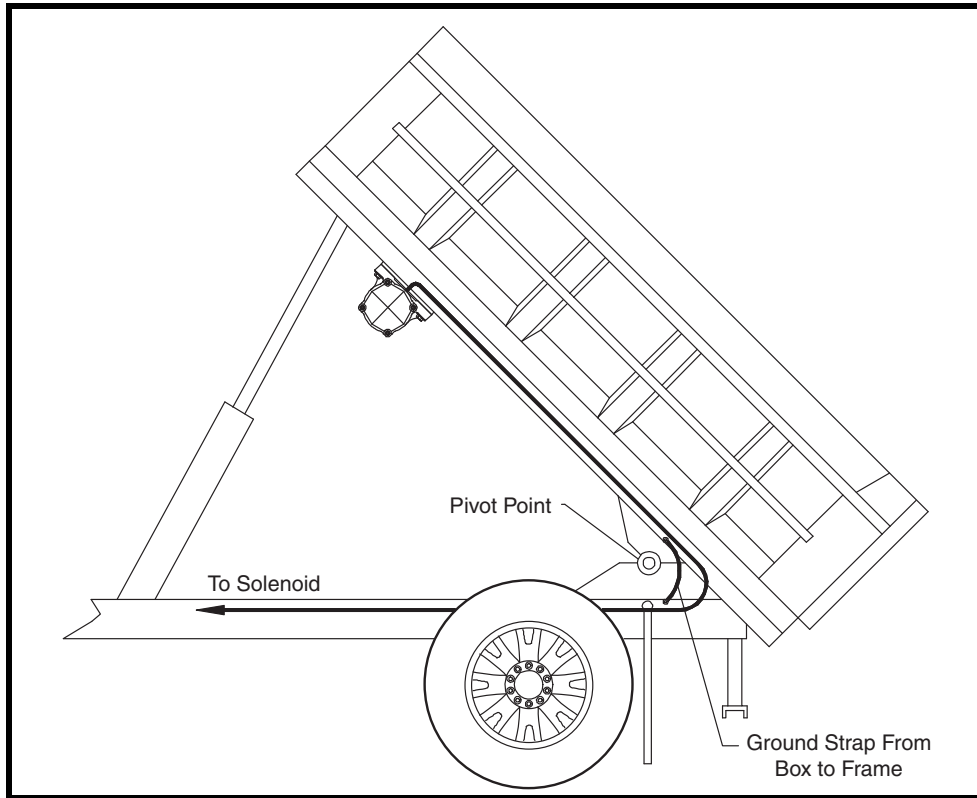

Figure 5. Ground Strap Connections

**Starting Cougar®
DC Truck
Vibrators**

IMPORTANT

The Cougar® DC Truck Vibrator is NOT guaranteed for continuous duty. The recommended duty cycle for Cougar® DC Truck Vibrators is a maximum of 45 seconds on-time and a minimum of 90 seconds off-time. Operation in excess of the recommended duty cycle could void the warranty.

1. Begin unloading truck in the normal manner.
2. Run vibrator briefly (45 seconds or less) when material has stopped flowing during unloading.
3. Run vibrator again to clean truck box at the end of the unloading cycle.

Troubleshooting

Symptom	Corrective Action
Vibrator will not reach required speed.	<ul style="list-style-type: none">• Check mount. If damaged, replace mount or stiffen mount by lengthening it or reinforcing structure wall.• Check voltage at motor. If voltage is lower than 12V DC, increase wire size or shorten lead length.
Vibrator will not start.	<ul style="list-style-type: none">• Check for blown fuse, failed power supply, loose or improper connections.• If push button or solenoid is not functioning, replace component.• Check for proper grounding.
Vibrator noisy.	<ul style="list-style-type: none">• Check for loose mounting bolts and re-torque.• Check mounting assembly and repair any broken welds.• Check for worn motor brushes or bearings. Contact dealer for replacement if necessary.

Maintenance

IMPORTANT

Read entire section before beginning work.

▲ WARNING

Turn off and lock out/tag out energy source before beginning work on any Cougar® DC Truck Vibrator.

1. Remove back cap on motor and inspect brushes for wear. If worn, replace brushes.

IMPORTANT

Care must be taken when removing bolts, as the field case also will be loose.

2. Inspect electrical cords for cuts or wear. Replace if wiring is showing through cord.
3. Make sure all fasteners are tight.
4. Inspect structure for cracks or fatigue. If found, repair before operating vibrator again.
5. Re-torque mounting bolts after first week of use, and once a month after to ensure efficient vibrator operation.

NOTE

Sealed ball bearings are permanently lubricated. No added lubrication is needed.

Part Numbers

This section provides product names and corresponding part numbers for Cougar® DC Truck Vibrator and related equipment. Please reference part numbers when ordering parts:

NOMENCLATURE

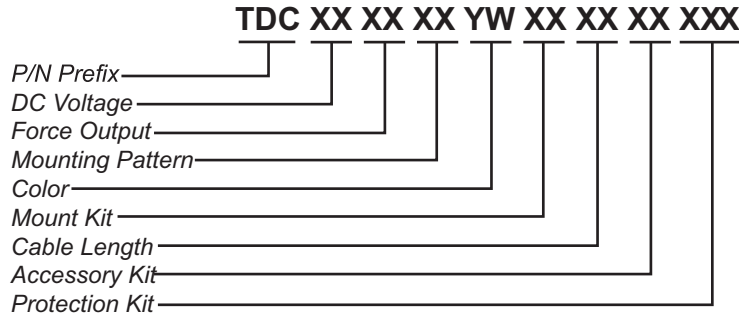

DC VOLTAGE

- 12:** 12 Volt
- 24:** 24 Volt

FORCE OUTPUT

- 11:** 1100 Lbs
- 16:** 1600 Lbs
- 25:** 2500 Lbs
- 27:** 2700 Lbs
- 32:** 3200 Lbs

MOUNTING PATTERN

- 4M:** Rectangular Pattern 2.00" x 8.00"
- 2V:** In-line Pattern 8.50" Between Center
- 2M:** In-line Pattern 8.00" Between Center

MOUNT KIT

- MO:** No Mount Kit
- MA:** Aluminum Mount Plate
- MS:** Steel Mount Plate
- MB:** Hardware Only

CABLE LENGTH

- CO:** No Cord
- 25:** 25 ft
- 40:** 40 ft
- 70:** 70 ft

ACCESSORY KIT

- AO:** No Accessory Kit
- 06:** #6 Kit

PROTECTION KIT

- PRO:** No Protection Kit
- 1CO:** 2-Year Warranty (circuit breaker)
- 3CT:** 3-Year Warranty (circuit breaker and timer)

Part Numbers

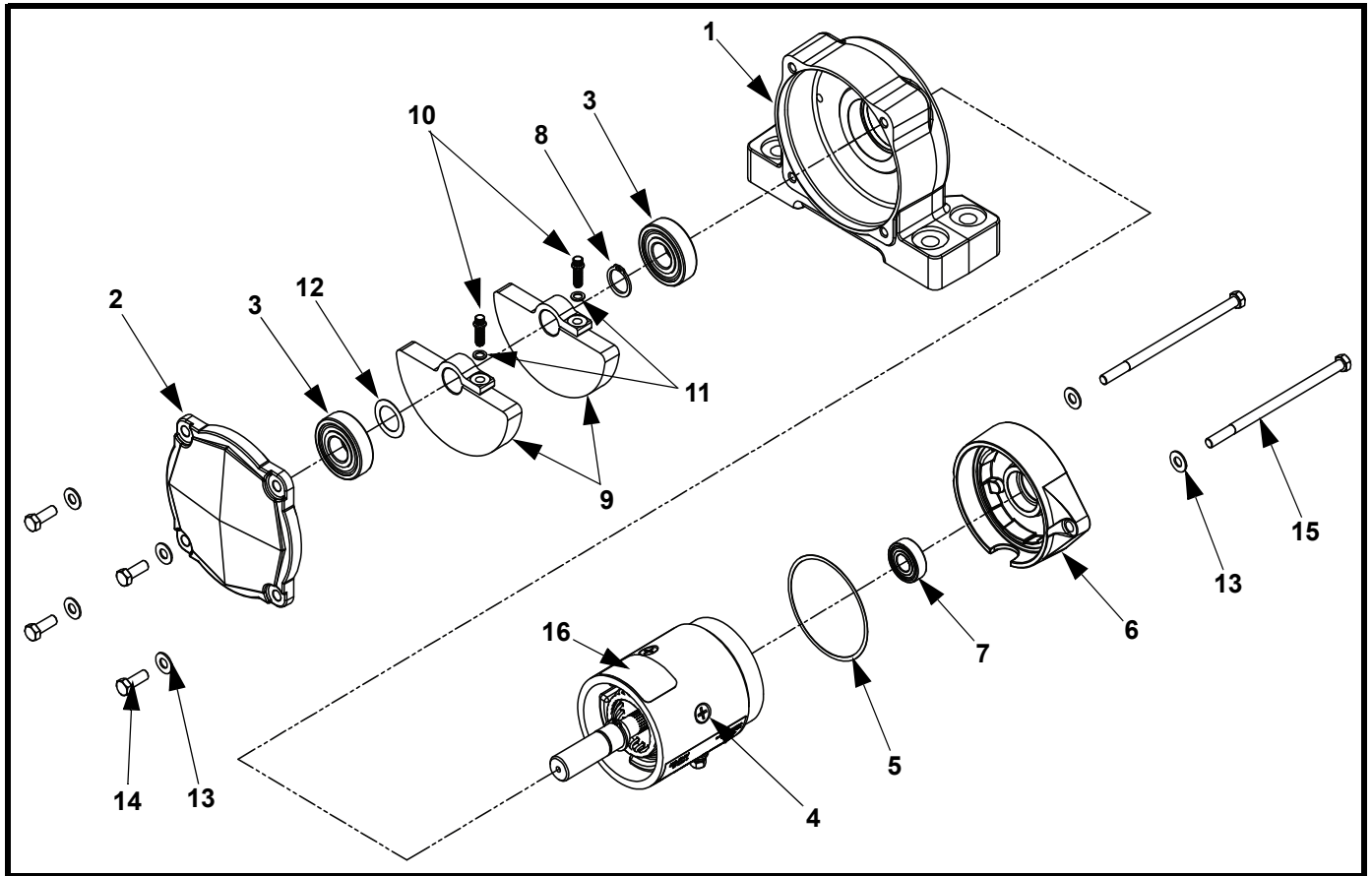

Figure 6. Cougar[®] DC Truck Vibrator Assembly, P/N TDC XX XX XX YW XX XX XX XXX

Item	Description	Part No.	Qty
1	Housing Machined	Table II	1
2	End Bell	120171	1
3	Bearing Ball 6305 2Z C3	CG-100104	2
4	Electric Motor Assembly	167559-XX*	1
5	Gasket	130006	1
6	End Bell Machined	120195	1
7	Bearing Ball 6203 2Z C3	CG-100107	1
8	Retaining Ring Ext Heavy Duty 1.00 Dia. Shaft	530313	1
9	Weight Eccentric	170711	Table II
10	Screw 12-point 5/16-18 x 7/8 Plain	CG-100423	Table II
11	Washer Schnorr D8	513004	Table II
12	Spacer Bearing	CG-100285	Table II
13	Washer Belleville 3/8; OD .813, THK .060 ZP	CG-517696	6
14	Screw HHC 3/8-16 x 1 GR5 ZP	500080	4
15	Screw HHC 3/8-16 x 7 GR5 ZP	500111	2
16	Label Caution for DC Vibrators	Form 123	1
17	Label Cougar USA Logo	CG-100427	2

* XX indicate Volts (12) or (24).

Table II. Cougar[®] DC Truck Vibrator Part Numbers and Quantities

Part No.	Part No. Item 1	Qty Item 9,10,11	Qty Item 12	Weight (lbs)
TDCXX-1100-2M-XX	110533-2M	2	1	23.8
TDCXX-1100-2V-XX	110533-2V	2	1	23.8
TDCXX-1100-4M-XX	110533-4M	2	1	23.7
TDCXX-1600-2M-XX	110533-2M	2	1	23.8
TDCXX-1600-2V-XX	110533-2V	2	1	23.8
TDCXX-1600-4M-XX	110533-4M	2	1	23.7
TDCXX-2500-2M-XX	110533-2M	1	0	20.6
TDCXX-2500-2V-XX	110533-2V	1	0	20.6
TDCXX-2500-4M-XX	110533-4M	1	0	20.6
TDCXX-2700-2M-XX	110533-2M	2	1	23.8
TDCXX-2700-2V-XX	110533-2V	2	1	23.8
TDCXX-2700-4M-XX	110533-4M	2	1	23.7
TDCXX-3200-2V-XX	110533-2V	2	1	23.8
TDCXX-3200-4M-XX	110533-4M	2	1	23.7

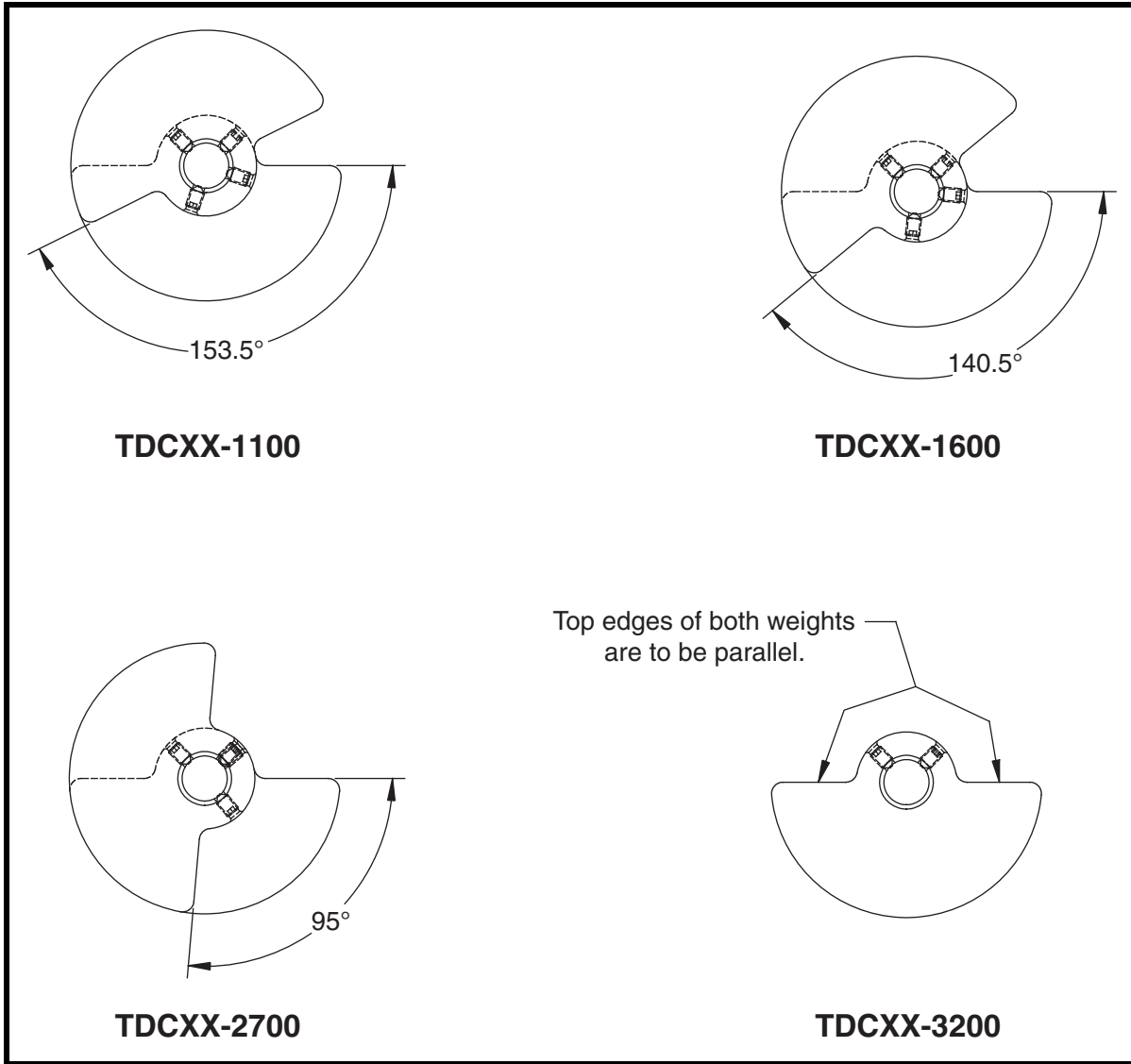

Figure 7. Eccentric Weight Settings



Any product, process, or technology described here may be the subject of intellectual property rights reserved by Martin Engineering Company. Trademarks or service marks designated with the ® symbol are registered with the U.S. Patent and Trademark Office and may be proprietary in one or more countries or regions. Other trademarks and service marks belonging to Martin Engineering Company in the United States and/or other countries or regions may be designated with the “TM” and “SM” symbols. Brands, trademarks, and names of other parties, who may or may not be affiliated with, connected to, or endorsed by Martin Engineering Company, are identified wherever possible. Additional information regarding Martin Engineering Company’s intellectual property can be obtained at www.martin-eng.com/trademarks.

AIRMATIC INC

airmatic.com | 215.333.5600 | infocenter@airmatic.com

