

Brute[®] **Vibrators**

[Go to Brute[®] Vibrators web page](#)



Operator's Manual **M3193**

Important

MARTIN ENGINEERING HEREBY DISCLAIMS ANY LIABILITY FOR: DAMAGE DUE TO CONTAMINATION OF THE MATERIAL; USER'S FAILURE TO INSPECT, MAINTAIN AND TAKE REASONABLE CARE OF THE EQUIPMENT; INJURIES OR DAMAGE RESULTING FROM USE OR APPLICATION OF THIS PRODUCT CONTRARY TO INSTRUCTIONS AND SPECIFICATIONS CONTAINED HEREIN. MARTIN ENGINEERING'S LIABILITY SHALL BE LIMITED TO REPAIR OR REPLACEMENT OF EQUIPMENT SHOWN TO BE DEFECTIVE.

Observe all safety rules given herein along with owner and Government standards and regulations. Know and understand lockout/tagout procedures as defined by American National Standards Institute (ANSI) z244.1-1982, *American National Standard for Personnel Protection - Lockout/Tagout of Energy Sources - Minimum Safety Requirements* and Occupational Safety and Health Administration (OSHA) Federal Register, Part IV, 29 CFR Part 1910, *Control of Hazardous Energy Source (Lockout/Tagout); Final Rule*.

The following symbols may be used in this manual:



Danger: Immediate hazards that will result in severe personal injury or death.



Warning: Hazards or unsafe practices that could result in personal injury.



Caution: Hazards or unsafe practices that could result in product or property damages.



Important: Instructions that must be followed to ensure proper installation/operation of equipment.



Note: General statements to assist the reader.

Table of Contents

Section	Page
List of Figures	ii
List of Tables	ii
Introduction	1
General	1
References	1
Safety	1
Materials required	1
Model identification	1
Cases	2
Series	2
Unit weights	2
Before Installing Vibrator	3
Installing Vibrator	4
Mounting vibrator onto structure	4
After Installing Vibrator	11
Starting hydraulic vibrators	11
Starting pneumatic vibrators	12
Adjusting eccentric weights	13
Troubleshooting	16
Hydraulic vibrators	16
Pneumatic vibrators	16
Monthly Maintenance	17
Hydraulic vibrators	17
Pneumatic vibrators	17
Clamp foot parts replacement (CCV units)	17
Lubrication	18
Greased units	18
Replacing 6A air motor vane	18
Replacing 2A air motor vane	19
Part Numbers	20
Appendix. Brute® Vibrator technical data	A-1



List of Figures

Figure	Title	Page
1	Typical Vibrator Mount Locations	5
2	Welding Channel to Bin	6
3	Vibrating Two Bins with One Vibrator	6
4	Mounting Vibrator to Wooden Bin	7
5	Mounting Vibrator to Concrete Bin	7
6	Locating Vibrator on Truck Bed	8
7	Mounting Bolt and Compression Washer Installation	8
8	Typical Brute® Vibrator Mounts	9
9	Removing Motor/Flange Assembly	14
10	Eccentric Weight Settings	14
11	8HA Hydraulic Motor Assembly, P/N 12965	23
12	2A Air Motor Assembly, P/N 27873	24
13	6A Air Motor Assembly, P/N 27874	26
14	CV2.02-H Assembly, P/N 205692	28
15	CV2.07-H Assembly, P/N 205693	30
16	CV2.6-H Assembly, P/N 205663	32
17	CV2.8 Case Assembly, P/N CV28-X-GC	34
18	CC2.8 Case Assembly, P/N CC28-X-GC	36
19	CCV4 Case Assembly, P/N CCV4-X-GC	38
20	DV6 Case Assembly, P/N DV6-X-GC	40
21	CCV6 Case Assembly, P/N CCV6-X-GC	42
22	Air Motor Caution Label	44

List of Tables

Table	Title	Page
I	Shipping Weights of Hydraulic Brute® Vibrators	2
II	Shipping Weights of Pneumatic Brute® Vibrators	2
III	Channel Selection	8
IV	Bolt Sizes and Torque	10
V	CV2.8 Case Assembly Part Numbers and Quantities	35
VI	CC2.8 Case Assembly Part Numbers and Quantities	37
VII	CCV4 Case Assembly Part Numbers and Quantities	39
VIII	DV6 Case Assembly Part Numbers and Quantities	41
IX	CCV6 Case Assembly Part Numbers and Quantities	43



General

Brute® Vibrators are equipped with motor-driven rotary eccentric weights that can be powered by a hydraulic or pneumatic motor, and deliver rotary vibration through a complete range of frequencies. The motor is attached to the separate head or case assembly containing the eccentric weights, bearings, and shaft. The motor shaft is inserted in the eccentric shaft and locked into place, which causes the eccentric weights to rotate with the motor shaft.

Brute® Vibrators are available in many different sizes and are available with portable or permanent mounts. Technical data for each Brute® Vibrator is provided in the Appendix.

References

The following documents are referenced in this manual:

- *The National Electrical Code (NEC)*. National Fire Protection Association, 1 Batterymarch Park, P.O. Box 9101, Quincy MA 02269-9101.
- American National Standards Institute (ANSI) z244.1-1982, *American National Standard for Personnel Protection - Lockout/Tagout of Energy Sources - Minimum Safety Requirements*, American National Standards Institute, Inc., 1430 Broadway, New York, NY 10018.
- Federal Register, Volume 54, Number 169, Part IV, 29 CFR Part 1910, *Control of Hazardous Energy Source (Lockout/Tagout); Final Rule*, Department of Labor, Occupational Safety Health Administration (OSHA), 32nd Floor, Room 3244, 230 South Dearborn Street, Chicago, IL 60604.

Safety

All safety rules in the above documents and all owner/employer safety rules must be strictly followed when working with this unit.

Materials required

Only standard hand tools are required to install and maintain this equipment.

Model identification

Each model of Brute® Vibrator is classified with an alphanumeric designation. Each letter and number represents a specific aspect of the vibrator.

Prefix letters:

- C = Two-bolt permanent mount
- CC = Quick-change or portable mount
- D = Six-bolt permanent mount
- V = Force output perpendicular to the mount

Model numbers:

- First digit = Eccentric weight radius (case) 2,4,6
- Second/Third letter designation = Unbalance (in.-lb) A=Air, H=Hydraulic

Example: CV 2.8 - H

- C = Two-bolt permanent mount
- V = Force output perpendicular to mount
- 2 = Eccentric weight radius (case)
- 8 = Unbalance (in.-lbs)
- H = Hydraulic Motor

Cases

Six different Brute® Vibrator Series cases are available: 2.02, 2.07, 2.6, 2.8, 4, and 6. The 2.07, 2.6, 2.8, 4, and 6 case vibrators feature adjustable eccentric weights to meet optimum force and frequency requirements.

Series

Four different Brute® Vibrator Series are available:

- **CCV:** Available in two sizes (CCV4 and CCV6). These units feature clamp feet for use as portable units.
- **DV:** Available in one size (DV6). These units are base-mounted for permanent installations.
- **CV:** Available in four sizes (CV2.02, CV2.07, CV2.6, and CV2.8). This unit has a base mount which can be used for permanent mounting. A bracket can also be used for portability for railcar unloading.
- **CC:** One size is available (CC2.8). This unit is mounted in a cradle lug bracket, and is ideal for concrete work where multiple lug brackets are used to mount the vibrator in various locations.

Unit weights

Tables I and II list shipping weights of all Brute® Vibrators.

Table I. Shipping Weights of Hydraulic Brute® Vibrators

Model No.	Weight lb (kg)
CV2.02-H	13 (5.9)
CV2.07-H	22 (10)
CV2.6-H	44 (20)
CC2.8-H	45 (20.4)
CV2.8-H	52 (23.6)
CCV4-H	60 (27.2)
CCV6-H	110 (50.0)
DV6-H	115 (52.2)

Table II. Shipping Weights of Pneumatic Brute® Vibrators

Model No.	Weight lb (kg)
CC2.8-A	45 (20.4)
CV2.8-A	49 (22.2)
CCV4-A	58 (26.3)
CCV6-A	110 (50.0)
DV6-A	115 (52.2)

IMPORTANT

The delivery service is responsible for damage occurring in transit. Martin Engineering CANNOT enter claims for damages. Contact your transportation agent for more information.

1. Inspect shipping container for damage. Report damage to delivery service immediately and fill out delivery service's claim form. Keep any damaged goods subject to examination.
2. Remove vibrator from shipping container.
3. If anything is missing or damaged, contact Martin Engineering or a representative.

▲WARNING

If equipment will be installed in an enclosed area, gas level or dust content must be tested before using a cutting torch or welding. Using a cutting torch or welding in an area with gas or dust may cause an explosion.

4. If using a cutting torch or welding, test atmosphere for gas level or dust content.
5. Make sure mounting surface is strong and flat, within 1/16 in. (2 mm) across vibrator feet. (This will prevent internal stress to vibrator casting when tightening mount bolts.)
6. Make sure mounting surface and vibrator are clean and free of debris.

Installing Vibrator

IMPORTANT

Read entire section before beginning work.

▲ CAUTION

If installation instructions are not followed, structure and vibrator can be damaged. Abusing or handling vibrator carelessly will accelerate wear and shorten bearing life.

▲ CAUTION

Never weld structure with vibrator mounted. Welding may cause damage to motor components and bearings.

IMPORTANT

The object of rotary vibration on bins, hoppers, and chutes is to transmit vibration through the wall into the product contained inside. If structure is not made rigid, vibrator may move material less efficiently.

IMPORTANT

Mounting plate should be mounted so that the vibrator shaft is at right angles to the length of the channel.

Mounting vibrator onto structure

1. See Figure 1. Locate vibrator in lower 1/4 to 1/3 of structure slope length. If second vibrator is required, mount 180° from first vibrator and halfway up slope.
2. If using reinforcing beam to strengthen hopper wall, do the following:
 - a. Locate reinforcing beam so vibrator can be positioned as shown in Figure 1.
 - b. Extend beam at least 3/4 the length of the sloped wall. Cut off end(s) of beam if necessary to fit on structure.
 - c. See Figure 2. Skip weld channel or beam onto hopper wall: Weld 3 in. (76 mm), then skip 2 in. (51 mm). Do not weld last 1 in. (25 mm) or either end of beam or any corner.
3. If using customer-supplied mounting plate to mount vibrator onto structure, do the following:
 - a. Make sure plate is at least size of vibrator base.
 - b. Locate plate so that vibrator can be positioned as shown in Figure 1.
 - c. Weld mounting plate onto structure.
4. If using cradle lug bracket or LBF mount, weld onto structure. (See Figure 8.)

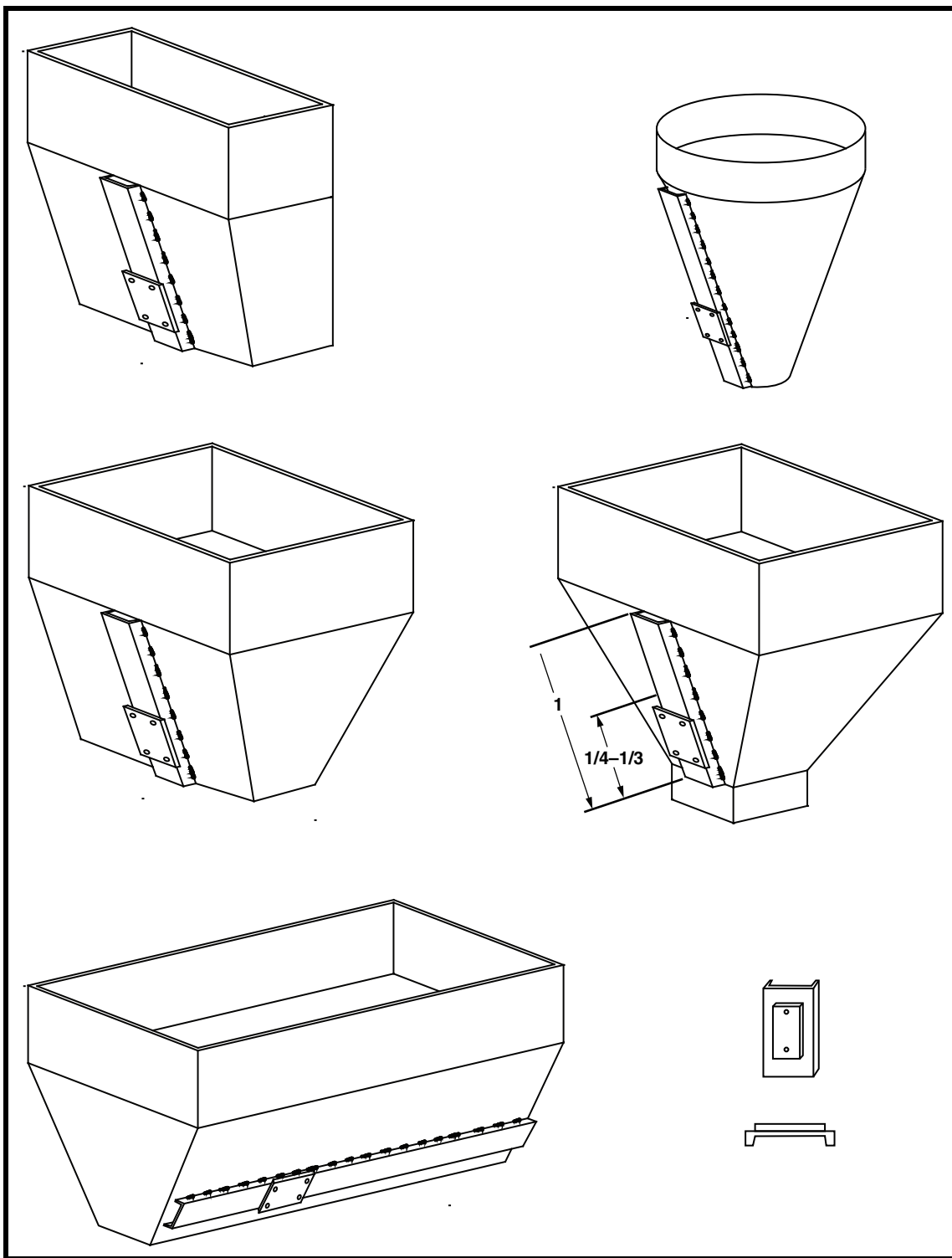

Figure 1. Typical Vibrator Mount Locations

Vibrator should be mounted on the center line of the side with the least slope, about 1/4 to 1/3 of the distance from the outlet to the top of the sloped side on a reinforced channel. If bin or hopper has one vertical side the vibrator must be mounted on the slope side opposite the vertical side.

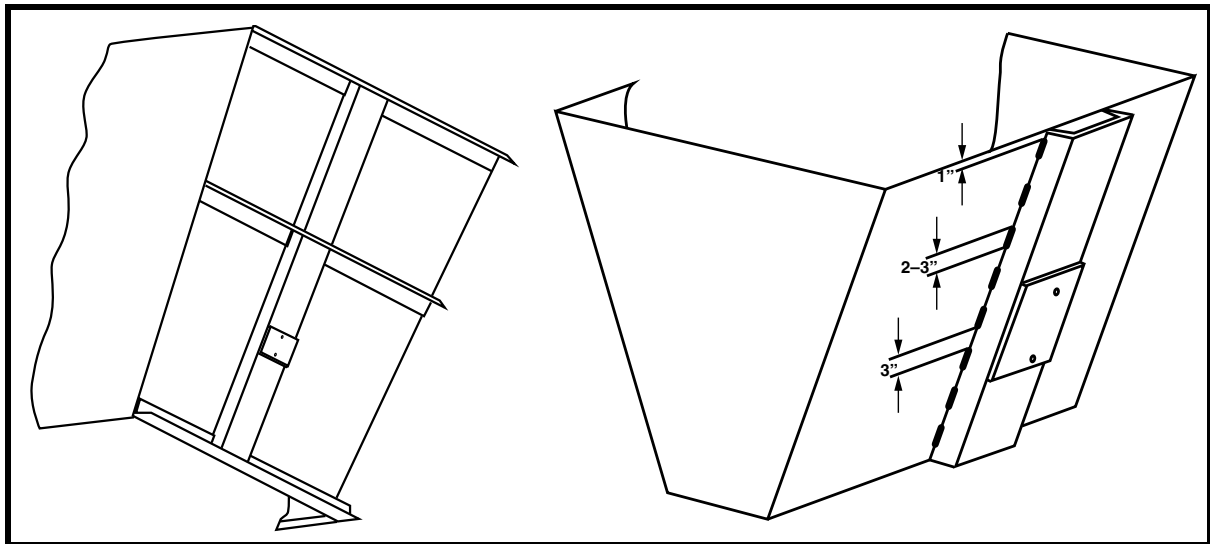

Figure 2. Welding Channel to Bin

A channel of recommended weight and size (see Table III) should be welded on the side with the least slope. Weld the legs of the channel to the bin wall, using skip welds (see Figure 2). Welds should be 2" -3" long with a 3" skip. Do not weld any closer than 1" from the end of the channel. If bin has a frame at the top and/or bottom weld solidly to this frame as shown in Figure 2. The vibrator mounting plate is then welded to this channel. All welding should be done with normal mild steel rod when attaching mounting assembly to mild steel structures. These same structural mild steel channels can be welded to a stainless steel hopper wall by using a rod of the same type stainless as the hopper wall.

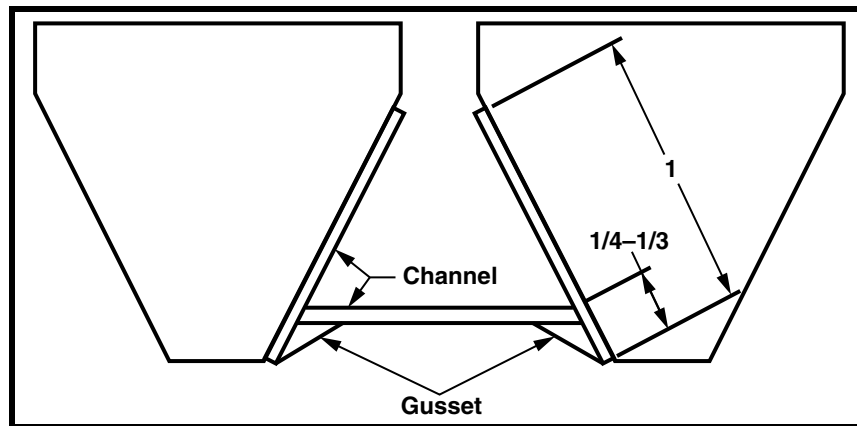

Figure 3. Vibrating Two Bins with One Vibrator

Although it is not recommended it is possible, in some applications to vibrate two bins with one vibrator. Follow reinforcing section carefully and tie bins together with heavy channel or "I" beam, gusset as shown or normal length of channel used for vibrator with 1/2 force of vibrator used for both bins.

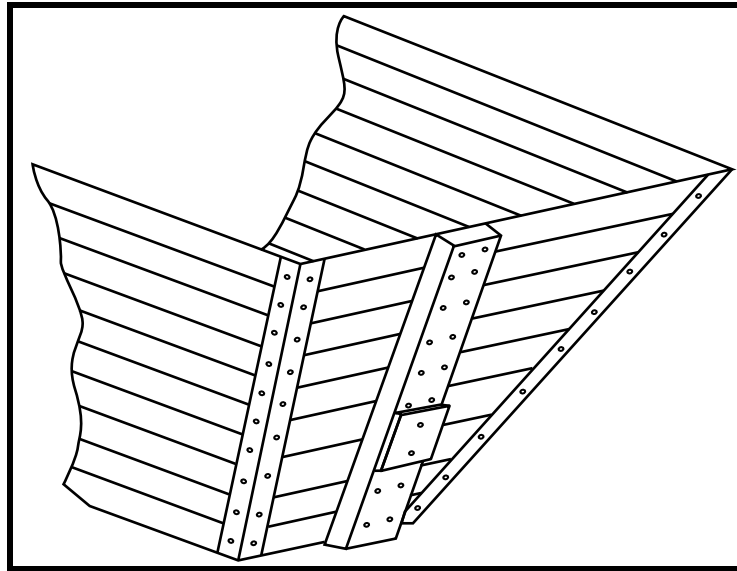

Figure 4. Mounting Vibrator to Wooden Bin

Wood bins and hoppers are difficult to vibrate and require more force and amplitude than similar steel structures. Vibrator should be mounted on the side with the least slope about $1/4 - 1/3$ of the distance from the outlet to the top of the slope side. A steel channel or plate of recommended size must be bolted directly to the planking with $5/8"$ or $3/4"$ carriage bolts. Use plenty of bolts, 2 or 3 to each plank depending upon plank width. Because wood dampens vibration, it may be advisable to bolt thru to a flat steel plate inside the bin, which will transmit the vibration to the contents.

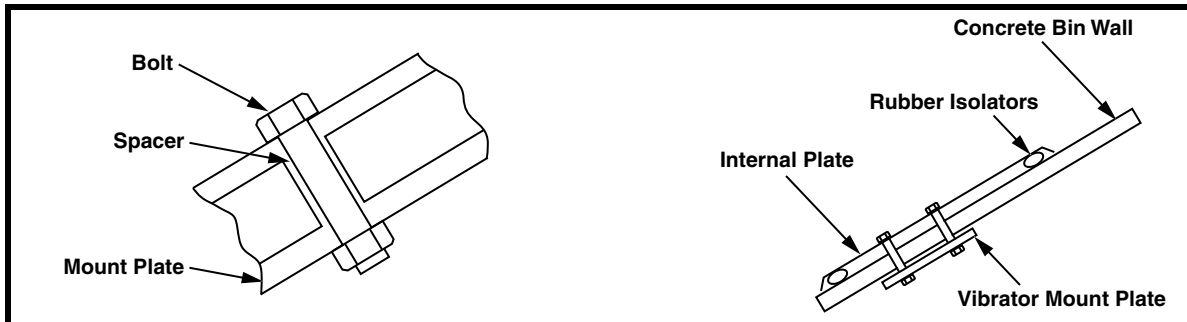

Figure 5. Mounting Vibrator to Concrete Bin

Material in concrete structures can be vibrated by mounting a steel plate inside the bin and vibrating it. The internal plate should be large and placed in a position that when the vibrator is mounted in the center of the plate, the vibrator will be in the lower $1/3$ of the bin on the slope side. The internal plate should be suspended on 4 rubber isolators to keep the plate from vibrating against the inside wall. The edges of the plate should be bent down toward the bin wall to keep material from accumulating under it. Four holes, larger than the spacer's diameter, are cored thru the bin's wall. The 4 cored holes must match the 4 holes drilled in the center of the internal plate. Cut spacers longer than the thickness of the bin wall and mount a heavy vibrator mounting plate to the internal plate thru the bin wall. The vibrator is then mounted to the outside plate.

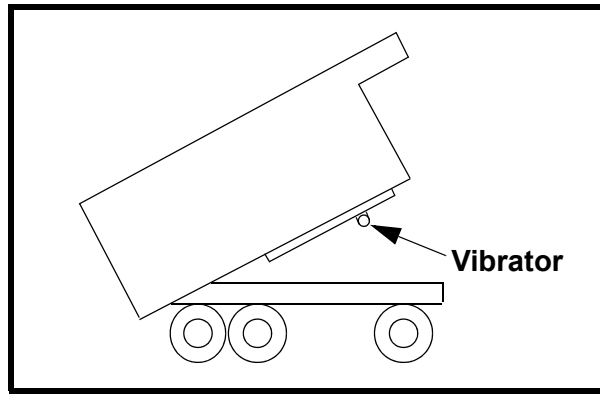

Figure 6. Locating Vibrator on Truck Bed

For trucks, mount vibrator in center of front 1/3 of truck bed on 6 by 4-in. (152 by 102-mm) channel, or on rigid member of truck bed. If two vibrators are required, mount 1/4 of width from each side in front 1/3 of truck bed.

Table III. Channel Selection

Maximum Available Force Pounds	Minimum Hopper Wall Thickness in. (mm)	Channel Length in. (mm)	Mounting Plate Thickness in. (mm)	Channel Size and Weight
200	7/64 (2.78)	18-24 (457-610)	1/4 (6.35)	4" channel 5.4 Lbs/ft
400	1/8 (3.18)	20-26 (508-152)	3/8 (9.53)	4" channel 5.4 Lbs/ft
900	3/16 (4.76)	36-48 (914-1219)	1/2 (12.70)	4" channel 5.4 Lbs/ft
1800	1/4 (6.35)	54-60 (1372-1524)	3/4 (19.05)	6" channel 10.5 Lbs/ft
3600	3/8 (9.53)	60-72 (1524-1829)	1 (25.40)	6" channel 10.5 Lbs/ft
5400	1/2 (12.70)	72-84 (1829-2134)	1-1/4 (31.75)	10" channel 20 Lbs/ft

Note: If hopper or bin wall is too thin, use two smaller vibrators equal in force to one large vibrator.

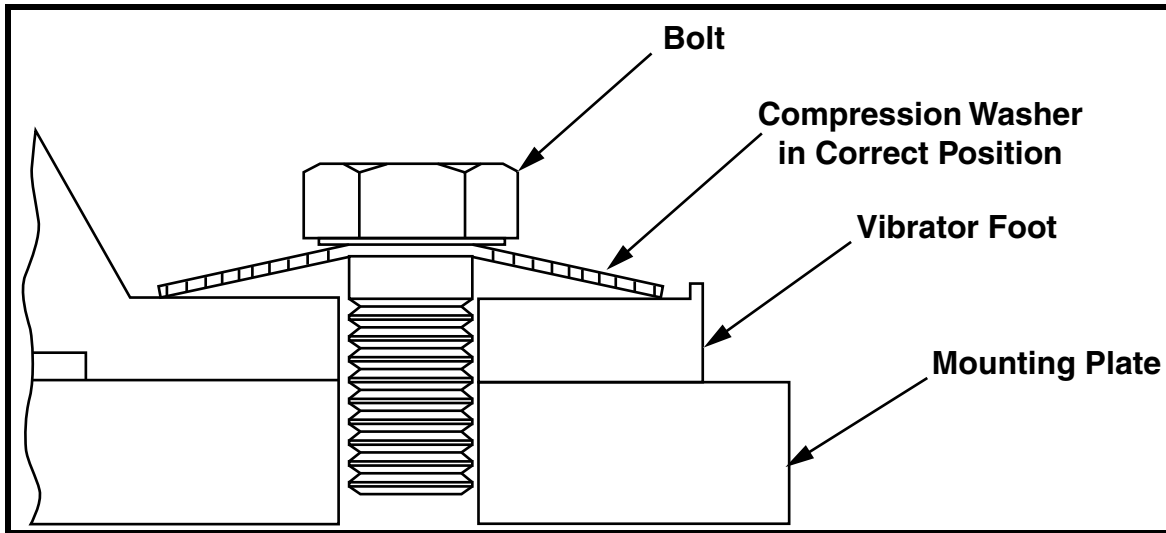

Figure 7. Mounting Bolt and Compression Washer Installation

NOTE

Cradle Lug series vibrators must be periodically tightened to not more than 130 ft/lbs max., and not less than 90 ft/lbs minimum.

▲ CAUTION

Never weld structure with vibrator mounted and wired. Welding may cause damage to motor components and bearings.

Use only new bolts, lock nuts, and compression washers to install vibrator. Old fasteners can break and cause damage to vibrator or structure.

Do not use split lock washers to install vibrator onto mount. Damage to vibrator could result.

5. Before installing vibrator onto mount, apply thread sealing compound to all bolts.
6. Install vibrator onto mounting plate with new Grade 5 lock nuts, compression washers, and bolts. See Table III for specific size and torque requirements. Use lock nuts and lock washers same size as bolts.
7. Install vibrator onto clamp mounts or LBM wedge as follows:
 - a. Align mounting holes in vibrator with mounting holes in mount.
 - b. Install vibrator onto mount with four new lock nuts, compression washers, and Grade 5 bolts. (See Table III for specific size and torque requirements.) Use lock nuts and lock washers same size as bolts.

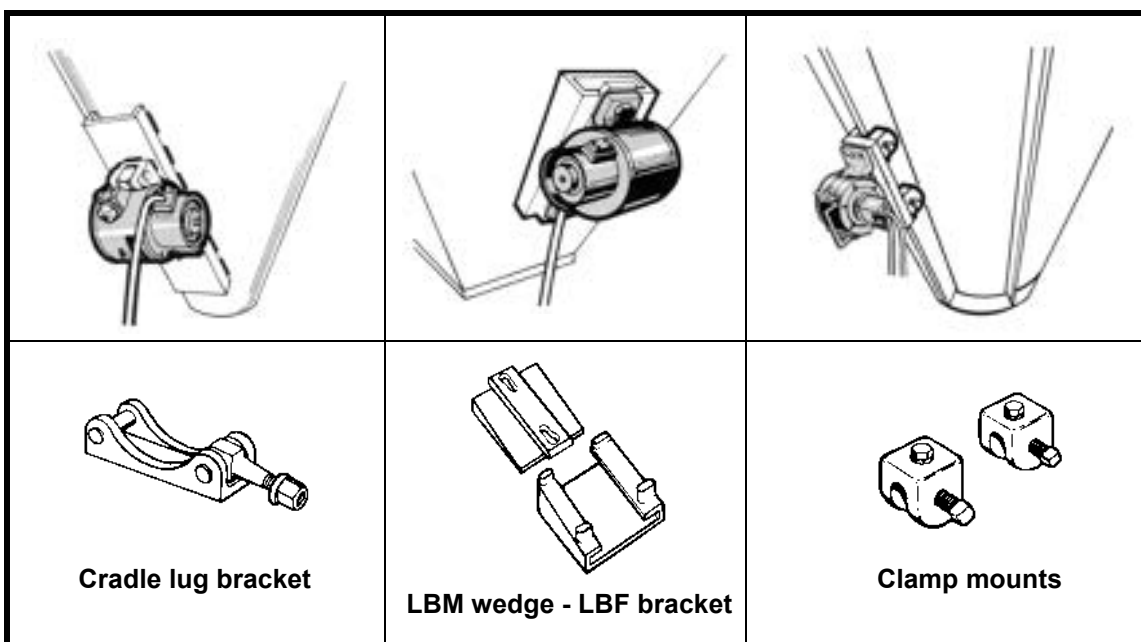

Figure 8. Typical Brute® Vibrator Mounts

8. After vibrator has operated for 10 to 20 minutes, check bolt torque. Tighten if necessary.

Table IV. Bolt Sizes and Torque

Bolt size	Bolt torque	
	ft-lb	kgm
1/2-in. - 13 NC	78 ft-lb	11
9/16-in. - 12 NC	114 ft-lb	16
5/8-in. - 11 NC	154 ft-lb	21
3/4-in. -10 NC	257 ft-lb	36
7/8-in. - 9 NC	382 ft-lb	53
1-in. - 8 NC	587 ft-lb	81

▲ WARNING

If vibrator is mounted more than 6 in. (152 mm) above ground, install cable securing vibrator to structure. Without cable, vibrator could fall and cause injury.

9. Secure vibrator to structure by installing Martin® BBAC Cable Kit, P/N 32271, or equivalent, as follows:
 - a. Weld D-ring onto structure wall above vibrator.
 - b. Loop 1/4-in. (6 mm) wire cable through vibrator handle and D-ring on structure wall.
 - c. Take up slack so cable is taut.
 - d. Apply thread sealing compound to nuts on cable clamps. Install four cable clamps (two on each) to secure cable to vibrator handle and D-ring. Torque cable clamps to 15-30 ft-lbs (2-4 kgm).
 - e. Trim loose ends of cable wire.

Starting hydraulic vibrators

▲ WARNING

Hydraulic oil under pressure can penetrate skin and result in injection poisoning. Special medical treatment is required for fluid injection injuries. If oil penetrates skin, see a doctor trained in fluid injection medicine immediately.

NOTE

Make sure hydraulic system has a filtration system, and that oil is industrial petroleum-based oil, SAE 10 to 30, with wear, oxidation, and foaming inhibitors, and a viscosity of 200 SSU.

1. Make sure hydraulic hoses are secured to hydraulic pump.
2. Apply plastic sealing compound to all fittings.

▲ CAUTION

Avoid dropping disconnected hydraulic pump hoses where dirt or material can get in fittings.

Do not overtighten hydraulic hose fittings. If original position of fittings must be changed, end plate assembly, case, and motor assembly drive plate must be clamped together as a unit to prevent misalignment of plates. Misalignment of plates will cause motor damage. Contact Martin Engineering for further instructions.

Make sure inlet hose fitting is on inlet motor fitting, and outlet hose fitting is on outlet motor fitting. Motor seal failure will result if fittings are incorrectly installed.

Make sure inlet hose is same size as inlet motor fitting, and outlet hose is one size larger than outlet motor fitting and larger than inlet hose.

3. Place hydraulic hose fittings on back of vibrator motor. Place inlet hose fitting on inlet vibrator motor fitting, and outlet hose fitting on outlet vibrator motor fitting. Tighten fittings.

IMPORTANT

Do not place flow-control valve on return line from motor. Return line must be free of restrictions or vibrator will not run correctly.

4. To control vibrator speed, place a flow-control valve on pressure side of motor.
5. Make sure hydraulic oil temperature does not exceed 150°F (65°C). (If oil temperature is above 150°F [65°C], a larger reservoir or heat exchanger on hydraulic pump may be required to allow better cooling.)

*Starting
pneumatic
vibrators*

6. Start vibrator and operate using specifications in Appendix Table A-I or A-II as a guide.

▲ CAUTION

Do not let inlet pressure exceed 1200 psi (82 bar). Seals will fail above 1200 psi (82 bar).

Remove pressure gauge after use. If pressure gauge is left on unit, gauge will be damaged.

7. Use a pressure gauge to check both inlet and outlet pressure at vibrator. If inlet pressure exceeds 1200 psi (82 bar) or outlet pressure exceeds 30 psi (2 bar), check for restrictive fittings or increase hose size. If fittings are not restricted, remove pressure gauge.

▲ WARNING

A Whip-Check or equivalent (hose connection safety device) should be used on all air line connections to prevent personnel injury if air line should become uncoupled under pressure.

▲ CAUTION

Only filtered, regulated, and lubricated air can be used on Brute® Pneumatic Vibrators. Warranty will be void if air does not meet these requirements.

Handle air line with care. Do not allow air line to drop on ground or dirt to enter. Dirt will restrict air flow.

1. Air line must be same diameter as inlet port diameter of vibrator motor. If air line is longer than 25 ft (7.62 m), use next diameter size air line.

▲ CAUTION

Over-lubrication will restrict air flow and reduce vibrator operating speed. Under-lubrication will damage vibrator motor.

Use only Martin® Air Motor Oil (P/N 14766) with this vibrator. Using other oils can damage vibrator and will void warranty.

2. Install air filter/regulator/lubricator on air line (see step 5 for cold weather instructions). Use Martin® Air Motor Oil only. Set lubricator to deliver 6 to 10 drops per minute.
3. Install Brute® Vibrator with Whip-Check on air line.
4. If using muffler, remove cover plate from exhaust port and install muffler on vibrator motor exhaust port.

▲ CAUTION

Use of de-icing agent in lubricator is necessary if in freezing conditions.

5. If using Brute® Pneumatic Vibrator in freezing weather (to 32°F [0°C]), do the following:
 - a. Use a 50/50 mix of Martin® Air Motor Oil and a nonflammable de-icing agent in lubricator. Set lubricator to deliver 6 to 10 drops per minute.
6. If using Brute® Pneumatic Vibrator in extreme cold weather or if Brute® is freezing up, do the following:
 - a. Install a second lubricator on air line between filter/regulator/lubricator and fill with a nonflammable de-icing agent to prevent condensation freezing. Set lubricator to deliver 1 to 3 drops per minute.

▲ CAUTION

Do not run vibrator over 80 psi (5.4 bar). Damage to vibrator will result.

7. Start vibrator and operate according to specifications in Appendix, Table A-III.

NOTE

Some Brute® Vibrators have adjustable eccentric weights. Weights are set at factory and this setting will serve for most applications. However, if adjustment is necessary, do so as instructed below.

▲ WARNING

Before adjusting eccentric weights, turn off and lock out/tag out energy source to vibrator.

1. Turn off and lock out/tag out energy source to vibrator according to ANSI standards (see “References”).

▲ CAUTION

Adjust both sets of eccentric weights to same setting number (mirror images), or force output will be uneven and damage vibrator.

2. Remove screws from back cover and pry cover from case.
3. If applicable, remove motor/flange to adjust weights on motor side of vibrator. Remove motor/flange as follows:
 - a. See Figure 9. Remove six 1-in. (25 mm) long hex head cap screws (A) from motor side of unit.
 - b. Loosen four motor screws (B) one turn.

Adjusting eccentric weights

- c. If motor assembly (C) is tightly engaged with case (D), remove the two 1/4-in. (6 mm) long hex head cap screws and replace them with two of the 1-in. (25 mm) long hex head cap screws removed in step 3.a.
- d. Evenly turn the two screws to push the motor flange away from the case. (If shaft is still not free, use two 1/4 -20 NC hex head cap screws that are 2-1/2 in. (64 mm) long.

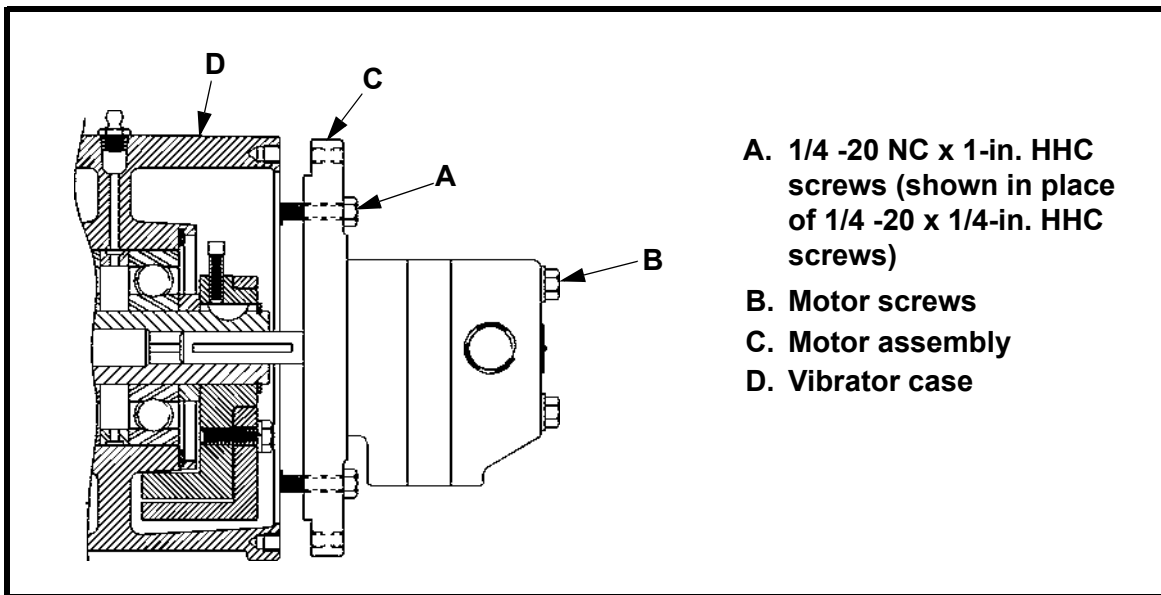
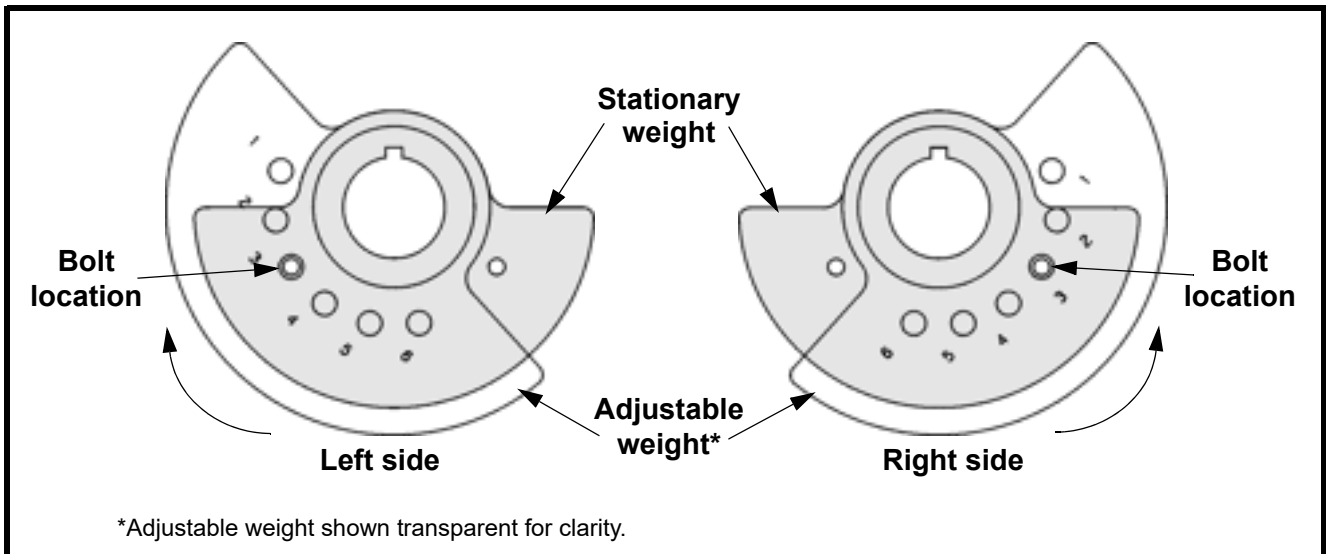

Figure 9. Removing Motor/Flange Assembly

- 4. Set adjustable eccentric weight as follows:
 - a. Remove hex head cap screw and lock washer from adjustable eccentric weight.
 - b. See Figure 9. Rotate adjustable eccentric weight to proper setting according to Appendix. Move weight to higher number to produce less force (i.e., highest number is minimum setting and lowest number is maximum setting).



*Adjustable weight shown transparent for clarity.

Figure 10. Eccentric Weight Settings

- c. Install hex head cap screw and lock washer through desired setting hole and into same hole on stationary weight bolt was removed from in step 4.a. Tighten to 8 ft-lb (1 kgm).

▲ CAUTION

Adjust both sets of eccentric weights to same setting number (mirror images), or force output will be uneven and damage vibrator.

- d. Repeat steps 4.a through 4.c for second set of weights. Set both sets of weights to same setting number so they are mirror images.
5. Apply teflon tape to screws, and install back cover and screws.

▲ CAUTION

Feather key must not come out of shaft when reinstalling motor. Shaft and key should assemble with little or no pressure. If key is displaced when reassembling, vibrator will be damaged.

6. Remove longer hex head cap screws from motor assembly and reinstall onto case.
7. Replace six 1-in. (25 mm) long screws and two 1/4-in. (6 mm) long screws and torque 8 to 10 ft-lb (1 to 1.4 kgm).
8. Torque four motor screws 8 to 10 ft-lb (1 to 1.4 kgm).

Troubleshooting

Hydraulic vibrators

Symptom	Corrective action
Gallons-per-minute flow to vibrator is less than required (see Table A-I and A-II).	Outlet hose is too small. Make sure outlet hose is one size larger than outlet motor fitting.

Pneumatic vibrators

Symptom	Corrective action
Vibrator will not reach required speed or exceeds psi rating.	<ul style="list-style-type: none"> • Vibrator is receiving too much or too little lubrication. Reset lubricator to deliver 6 to 10 drops per minute. • Air filter is clogged. Clean or replace air filter. • Air line from compressor to vibrator is too small for cfm requirements. Check valves, gauges, and air line diameter. Replace with bigger air line. • Air line is restricted or leaking. Replace or repair air line. • Regulator is faulty or leaking. Replace or repair regulator. • Compressor is not delivering required cfm. Replace with larger compressor. • Muffler is clogged. Clean or replace muffler.

Hydraulic vibrators

▲ WARNING

Hydraulic oil under pressure can penetrate skin and result in injection poisoning. Special medical treatment is required for fluid injection injuries. If oil penetrates skin, see a doctor trained in fluid injection medicine immediately.

1. Use cardboard to inspect hoses and fittings for leaks.
2. Inspect oil. If dark or thick, replace.

▲ CAUTION

Do not overtighten hydraulic hose fittings. Damage to fittings and motor will result.

3. Make sure all fasteners are tight.
4. Inspect structure for cracks or fatigue. If found, repair before operating vibrator again.

Pneumatic vibrators

1. Inspect air filter in hose whip filter assembly for dirt. If dirty, clean or replace filter.
2. Inspect air line filter for dirt. If dirty, clean or replace filter.
3. If using a muffler, clean muffler with industrial solvent.
4. Inspect air line from compressor to vibrator and all connections for leaks, dirt, or damage. Clean or replace as necessary.
5. Make sure lubricator(s) are filled and delivering 6 to 10 drops per minute.
6. Make sure all fasteners are tight.
7. Inspect structure for cracks or fatigue. If found, repair before operating vibrator again.

NOTE

Clamp foot parts replacement (CCV units)

Thread sealing compound has been applied to hex head set screw and bushings. You may need to heat clamp feet to 300°F (149°C) to release bond of thread sealing compound.

1. Remove hex head set screw and both bushings. If necessary, apply heat to clamp feet.
2. Remove all thread sealing compound from threads of hex head set screw and both bushings.
3. Inspect parts for wear. If worn, discard old parts and replace as follows:
 - a. Apply thread sealing compound to threads of hex head set screw and both bushings.
 - b. Install static bushing in back side of unit. Tighten to 250 ft-lb (35 kgm) for all CCV units.

- c. Install clamp block bushing in motor side of unit. Tighten to 250 ft-lb (35 kgm) for all CCV units.
- d. Install hex head set screw in motor side of unit. Tighten to 250 ft-lb (35 kgm) for CCV4 units and 450 ft-lb (62 kgm) for CCV6 units.

NOTE***Lubrication***

All models containing a suffix letter GC have greased case.

Greased units

Using Martin® Grease (P/N 16994) or equivalent rated for -65°F (-18°C) to +350°F (177°C), lubricate units as follows:

1. Turn off and lock out/tag out any energy source from vibrator according to ANSI standards (see “References”). Disconnect all hoses from air or hydraulic source.
2. Remove plastic cap (if present) from grease fitting.

▲ CAUTION

Do not over-lubricate vibrator. Over-lubrication can cause premature bearing failure.

3. Models CV2.02, CV2.07, and CV2.6 are lubricated for life.
4. Lubricate CC2.8, CV2.8, and CCV4 vibrators every 500 hours of operation with .25 oz of grease in grease fitting.
5. Lubricate CCV6 and DV6 vibrators every 500 hours of operation with .50 oz of grease in grease fitting.

Replacing 6A air motor vane

1. Remove hex head cap screw (1) and retaining ring (3).
2. Screw 3/8 by 2-in. bolt into hole on top of dead end plate (5) until plate is out of air motor body (15).
3. Remove old vanes (8).

▲ CAUTION

When cleaning vane/rotor area, do not remove rotor (7).

4. Clean vane/rotor area. Do not remove rotor.
5. Lightly oil new vanes with Martin® Air Motor Oil (P/N 14766) and install vanes.
6. Install dead end plate so o-ring (9) is aligned with hole A in stator.
7. Lightly tap on dead end plate until seated.
8. Install retaining ring. Lightly tap until seated.
9. Place 1 cc of Martin® Air Motor Oil in inlet and rotate shaft.
10. Install hex head cap screws and tighten.

Replacing 2A air motor vane

1. Remove socket head cap screw (17) and front plate (13).
2. Remove old vanes (5).



When cleaning vane/rotor area, do not remove rotor (4).

3. Clean vane/rotor area. Do not remove rotor.
4. Lightly oil new vanes with Martin® Air Motor Oil (P/N 14766) and install vanes.
5. Align front plate with dowel pin (11) holes.
6. Lightly tap on front plate until seated.
7. Place 1 cc of Martin® Air Motor Oil in inlet and rotate shaft.
8. Install socket head cap screws and tighten.

Part Numbers

This section provides part numbers for Brute® Vibrators and related equipment. Please reference part numbers when ordering parts. Refer to Figures 11 through 13 for motor part numbers and 14 through 22 for case part numbers.

▲ CAUTION

All Brute® Vibrator motors must be returned to Martin Engineering for warranty motor repair. Warranty will be void if vibrator is returned disassembled while under warranty.

Case Model	Assembly Part No.	Case assembly Part No.	Motor Part No.	Motor Model/Type
CV2.02	205692	110208	210022	Hydraulic
CV2.07	205693	110207	210022	Hydraulic
CV2.6	205663	110197	210022	Hydraulic
CC2.8	CC28-H-GC	18030	12959	5HB Hydraulic
CC2.8	CC28-A-GC	18030	27873-CC2.8	2A Pneumatic
CV2.8	CV28-H-GC	17497	12959	5 HB Hydraulic
CV2.8	CV28-A-GC	17497	27873	2A Pneumatic
CCV4	CCV4-H-GC	22777	12959	5HB Hydraulic
CCV4	CCV4-A-GC	22777	27873-CCV4	2A Pneumatic
CCV6	CCV6-H-GC	22776	12965	8HA Hydraulic
CCV6	CCV6-A-GC	22776	27874	6A Pneumatic
DV6	DV6-H-GC	22092	12965	8HA Hydraulic
DV6	DV6-A-GC	22092	27874	6A Pneumatic

NOTE

If specific mounts are not listed for your Brute® Vibrator, contact Martin Engineering for assistance in selecting a mount.

Mounts

Clamp blocks for CV2.8: P/N 12958-05.

Cradle Lug Bracket: P/N 28732.

LBM - LBF Mount: LBM P/N 10087, LBF P/N 12735. (LBF is female half of railroad car vibrator wedge and can be welded or bolted onto structure. LBM is male half of wedge.)

Repair kits for air motors**2A Service Kit:** P/N 210357.**6A Vane Kit:** P/N 31543.**6A Dead end:** P/N 33207.**6A Live end:** P/N 33208.***Miscellaneous*****Martin® Air Motor Oil:** P/N 14766 (one quart), P/N 14767 (case).**Martin® Grease:** P/N 16994.**Martin® Whip-Check for 1/4-in. Air Line:** P/N 20630.**3/4-in. hose whip assembly:** P/N 17971.**1/2-in. hose whip assembly:** P/N 17970.**BBAC Cable Kit:** P/N 32271. (Kit includes D-ring, cable, cable clamps, and clamp hardware.)**Muffler for 3/4-in. Air:** P/N 19665.**Muffler for 1/2-in. Air:** P/N 210317

AIRMATIC INC

airmatic.com | 215.333.5600 | infocenter@airmatic.com



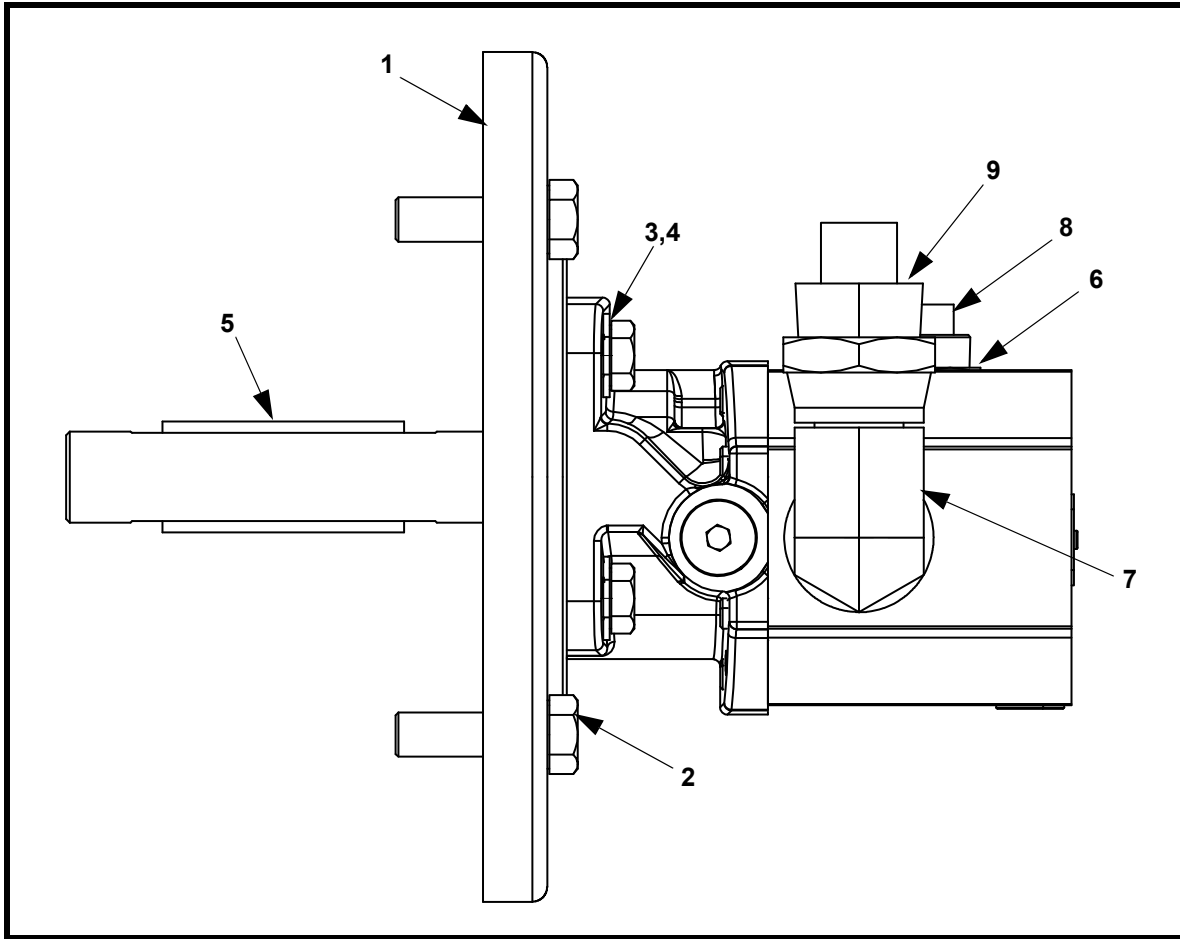

Figure 11. 8HA Hydraulic Motor Assembly, P/N 12965

Item	Description	Part Number	Qty
1	Motor flange	12967	1
2	Screw HHC 3/8-16NC x 1-1/4 ZP	CG-500082	4
3	Washer Belleville 5/16	CG-517694	4
4	Screw HHC 5/16-18NC x 7/8 ZP	SUS10088	4
5	Motor 8HA Hydraulic	26020-02P	1
6	Elbow Pipe/Swivel 1/2 NPTF x 1/2 NPSM Swivel 90 Degree	13368	1
7	Elbow Pipe/Swivel 1/2 NPTF x 3/4 NPSM Swivel 90 Degree	13387	1
8	Plug Pipe 1/2-NPT Sq Hd Plastic	12519	1
9	Plug Pipe 3/4-NPT Sq Hd Plastic	12823	1

Figure 11. 8HA Hydraulic Motor Assembly, P/N 12965

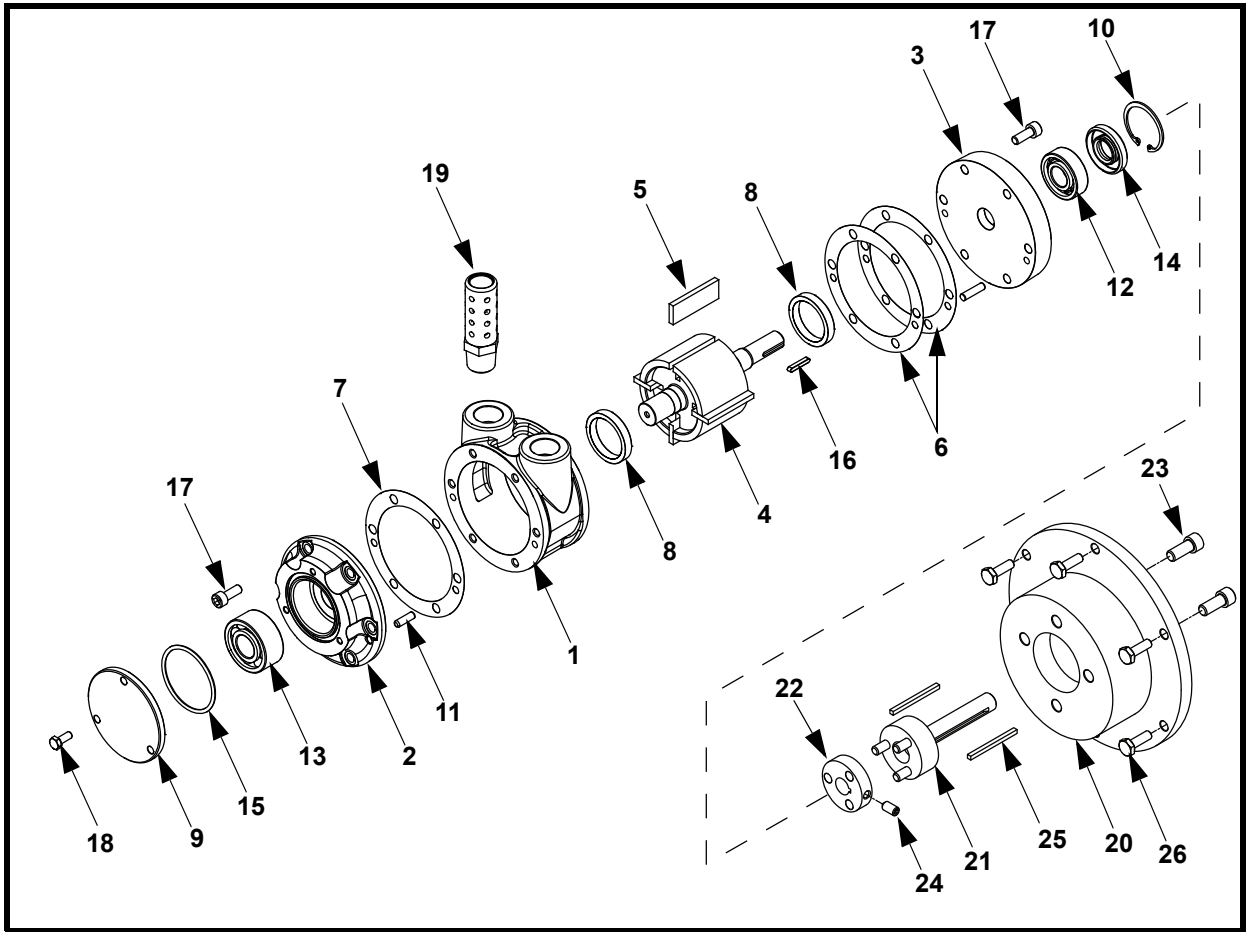

Figure 12. 2A Air Motor Assembly, P/N 27873 (sheet 1 of 2)

Item	Description	Part Number	Qty
1*	Body	210338	1
2*	End Plate	210339	1
3*	Front Plate	210340	1
4*	Rotor	210341	1
5*	Vane	210342	4
6*	Gasket – Red	210343	1
7*	Gasket – Green	210344	1
8*	Ejection Ring	210345	2
9*	Cover Plate	210346	1
10*	Snap Ring	210347	1
11*	Dowel Pin	210349	4
12*	Bearing	CG-100141	1
13*	Bearing	210351	1
14*	Oil Seal	210352	1
15*	O-Ring	210353	1
16*	Key Parallel 1/8 x 1/8 x 3/4	520808	1
17*	Screw SHC M6–1.0mm x 16mm PF	515611	12
18*	Screw HHC M5–0.8mm x 12mm ZP	210355	3
19*	Muffler	210317	1
20	Face Plate	120161	1
21	Drive Shaft	150329	1
22	Drive Ring	170526	1
23	Screw SHC 5/16-18NC-3A x 3/4	501244	4
24	Screw Set Knurl-Grip HSCP 1/4-20NC x 1/2 BO	519884	1
25	Key 1/8 x 1/8 x 1-3/4	520807	2
26	Screw HHC 1/4-20NC x 3/4	500003	6

*Included in 2A Air Motor, P/N 210251-03.

Figure 12. 2A Air Motor Assembly, P/N 27873 (sheet 2 of 2)

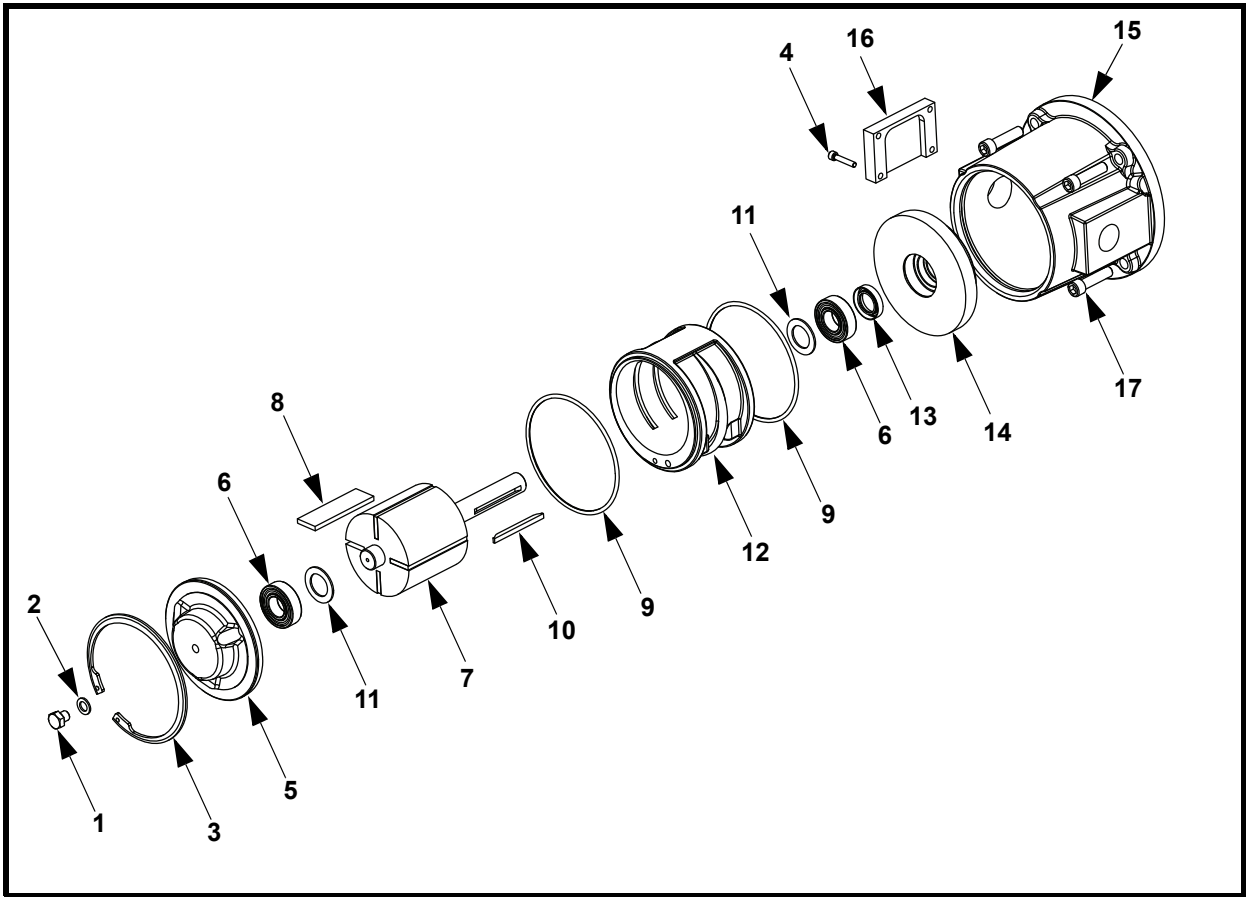

Figure 13. 6A Air Motor Assembly, P/N 27874 (sheet 1 of 2)

	6A
Exhaust	1 - 11-1/2 NPT
Inlet	3/4 - 14 NPT

Item	Description	Part Number	Qty
1	Screw HHC 3/8-16NC x 3/8	12518	1
2	Washer Fiber 3/8	11854	1
3	Retaining Ring	11860	1
4	Screw SHC #10-24NC-3A x 1.00	11872	4
5	Plate Dead End	33304	1
6	Bearing	26630	2
7	Rotor	26683	1
8*	Vane	29750	4
9	O-ring	11859	2
10	Key	11869	2
11	Washer Shim Ring M20	32926-01	2
12	Stator	26587	1
13	Seal Shaft	11873	1
14	Plate Live End	33306	1
15	Body 6A	10924	1
16	Plate Exhaust Cover	11049	1
17	Screw SHC 3/8-16NC-3A x 1-1/2	501277	4
18 (NS)	Label Inlet	22874	1
19 (NS)	Label Air Motor Lube Caution	22765	1
20 (NS)	Plug Pipe 3/4 NPT	12823	1
21*	O-ring	12017	1

**Included in 6A Service Kit, P/N 31543.*

Figure 13. 6A Air Motor Assembly, P/N 27874 (sheet 2 of 2)

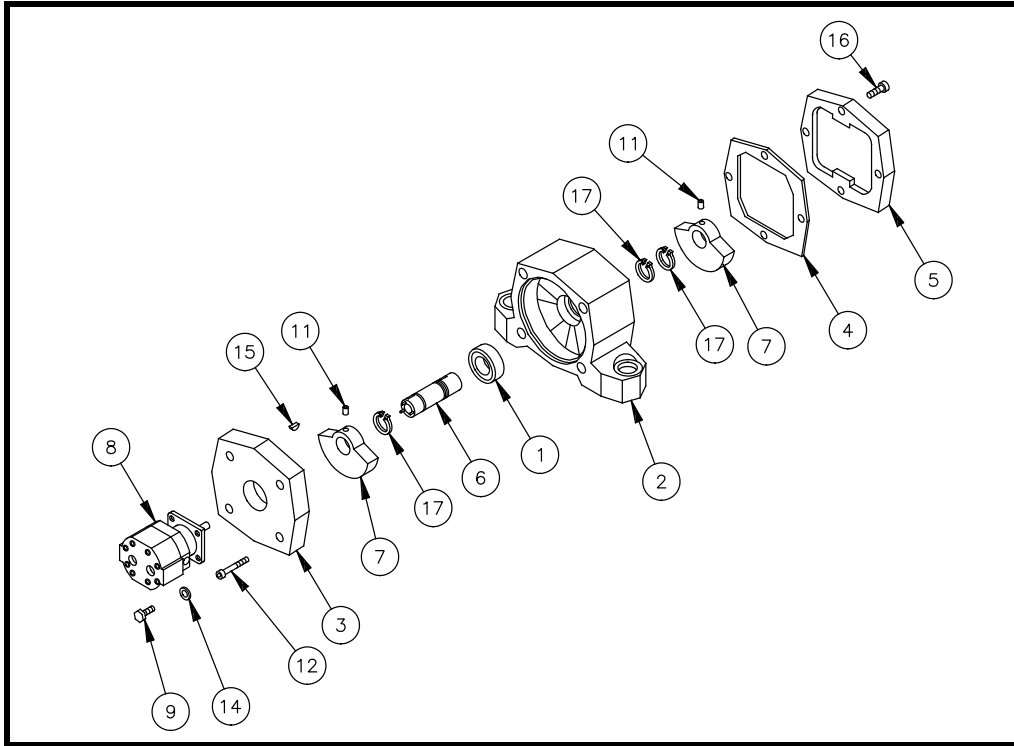

Figure 14. CV2.02-H Assembly, P/N 205692 (sheet 1 of 2)

Item	Description	Part Number	Qty
1	Bearing Single Ball with Double Shield	CG-100101	2
2	Housing	110208	1
3	Faceplate	120144	1
4	Gasket	130004	1
5	End Cap	130159	1
6	Shaft	155010	1
7	Weight Eccentric Stationary	170463	2
8	Hydraulic Motor	210022	1
9	Screw HHC 5/16-18NC x 3/4 ZP	500039	4
10 (NS)	Screw HHCS 3/8-16NC x 1-1/4 ZP	CG-500082	2
11	Screw SHC #8-32NC-3A x 1/2	501176	2
12	Screw SHC 1/4-20NC-3A x 3/4	501216	4
13 (NS)	Washer Compression 3/8 ZP	CG-517696	2
14	Washer Lock Helical Spring 5/16 ZP	CG-517799	4
15	Key Woodruff 1/8 x 1/2 #404	520798	1
16	Screw RHMS Slot #8-32NC x 3/4 ZP	521062	4
17	Retaining Ring	530228	3
18 (NS)	Label	21314	1
19 (NS)	Label	CG-100328-2	1

Figure 14. CV2.02-H Assembly, P/N 205692 (sheet 2 of 2)

Part Numbers

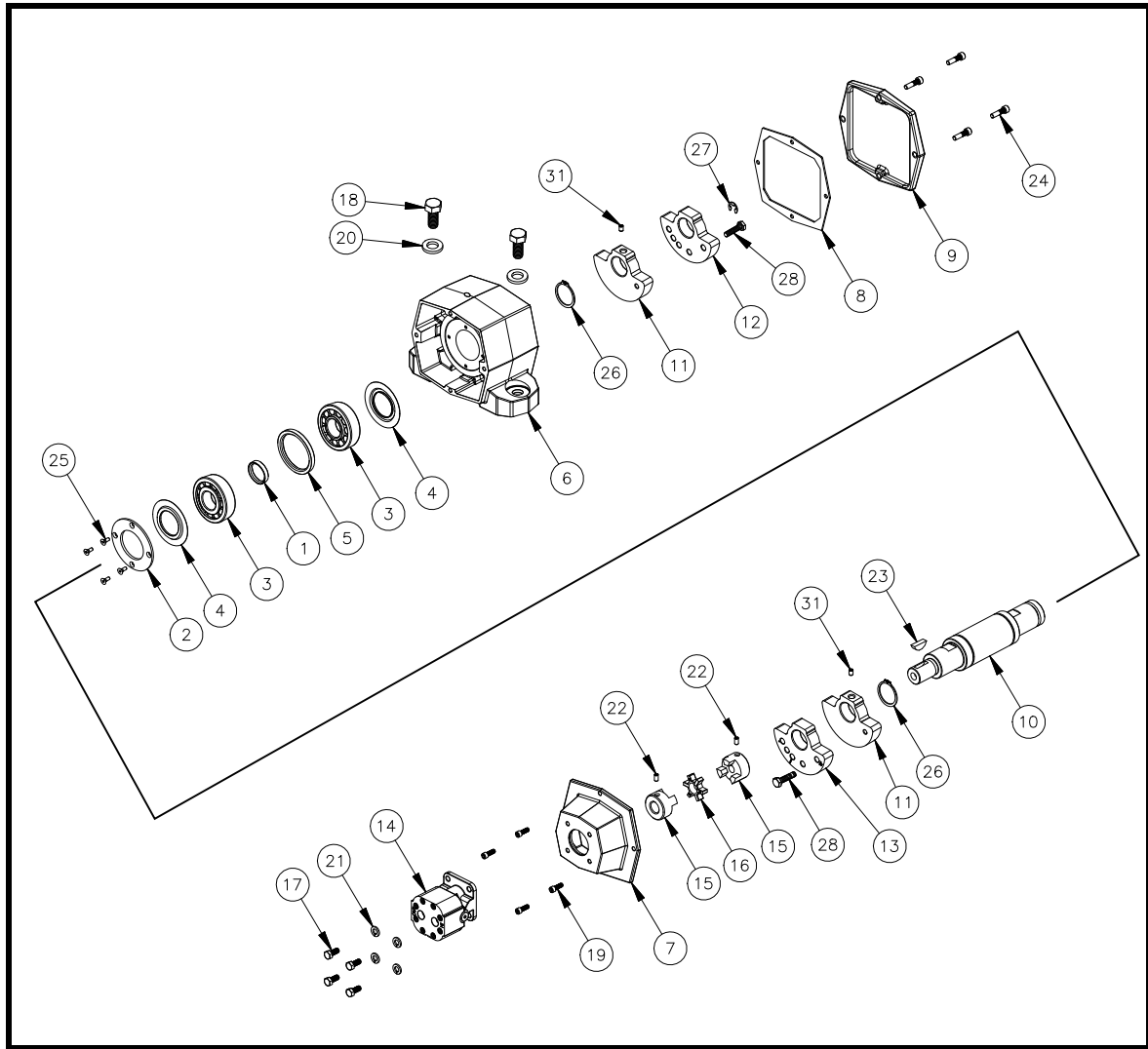

Figure 15. CV2.07-H Assembly, P/N 205693 (page 1 of 2)

Item	Description	Part Number	Qty
1	Bearing Spacer	CG-100224	1
2	Bearing Retainer	CG-100225	1
3	Bearing Roller	CG-100226	2
4	Seal	CG-100227	2
5	Bearing Spacer	CG-100235	1
6	Housing	110207	1
7	Faceplate	120146	1
8	Gasket	130004	1
9	End Cap	130159	1
10	Shaft	155012	1
11	Weight Eccentric Stationary	170471	2
12	Weight Eccentric Adjustable Right	170472	1
13	Weight Eccentric Adjustable Left	170473	1
14	Hydraulic Motor	210022	1
15	Coupling Jaw	217529	2
16	Spider with 3/4 Dia. Hole	217505	1
17	Screw HHC 5/16-18NC x 3/4 ZP	500039	4
18	Screw HHC 1/2-13NC x 1-1/2 ZP	500178	2
19	Screw SHC 1/4-20NC-3A x 3/4	501216	4
20	Washer Compression 1/2 ZP	517702	2
21	Washer Lock Helical Spring 5/16 ZP	CG-517799	4
22	Screw Set Knurl-Grip HSCP 1/4-20NC x 1/2	519884	2
23	Key Woodruff 1/8 x 1/2 #404	520798	1
24	Screw RHMS Slot #8-32NC x 3/4 ZP	521062	4
25	Screw HSFCHC #10-32NF x 1/2 ZP	522276	4
26	Retaining Ring Ext	530312	2
27	"E" Retaining Ring	531000	1
28	Screw HHC #10-32NF x 3/4 ZP	SUS10128	2
29 (NS)	Label Serial Number	21314	1
30 (NS)	Label	CG-100328-2	1
31	Screw Set Knurl Grip HSCP 1/4-20NC x 5/16	SUS10055	2

Figure 15. CV2.07-H Assembly, P/N 205693 (page 2 of 2)

Part Numbers

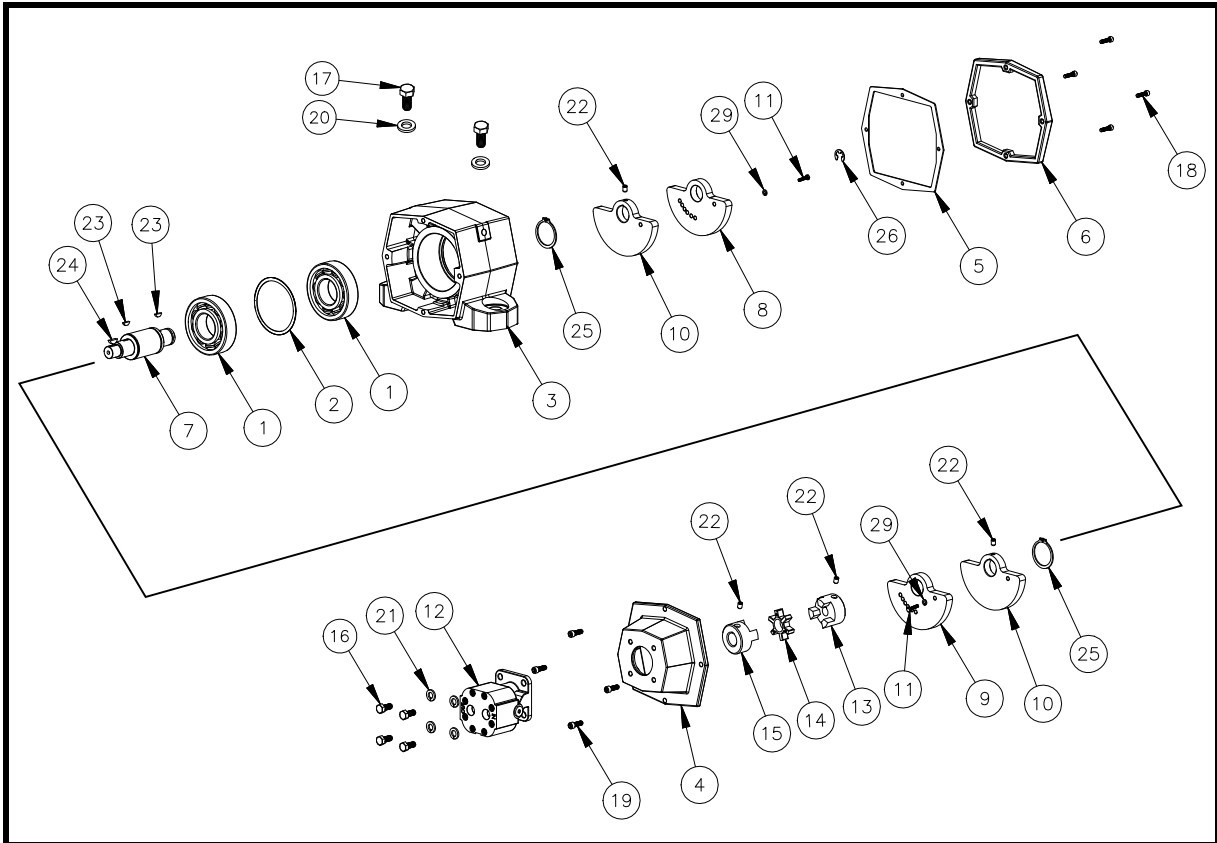

Figure 16. CV2.6-H Assembly, P/N 205663 (page 1 of 2)

Item	Description	Part Number	Qty
1	Bearing Single Ball with Double Shield	CG-100228	2
2	Spacer	CG-100237	1
3	Housing	110197	1
4	Faceplate	120142	1
5	Gasket	130002	1
6	End Cap	130143	1
7	Shaft	155011	1
8	Weight Eccentric Adjustable Right	170452	1
9	Weight Eccentric Adjustable Left	170453	1
10	Weight Eccentric Stationary	170554	2
11	Screw HHCS #10-32NF x 1 GRD8 ZP	SUS10128	2
12	Hydraulic Motor	210022	1
13	Coupling Jaw	217501	1
14	Spider with 3/4 Dia. Hole	217502	1
15	Coupling Jaw	32554	1
16	Screw HHCS 5/16-18NC x 3/4 Gr5 ZP	500039	4
17	Screw HHCS 5/8-11NC x 1-3/4 Gr5 ZP	500262	2
18	Screw SHC #10-32NF-3A x 3/4 PF	501196	4
19	Screw SHC 1/4-20NC-3A x 3/4	501216	4
20	Washer Compression 5/8 ZP	CG-517705	2
21	Washer Lock Helical Spring 5/16 ZP	CG-517799	4
22	Screw Set Knurl-Grip HSCP 1/4-20NC x 1/2 BO	519884	4
23	Key Woodruff 1/8 x 1/2 #404	520798	2
24	Key Woodruff 3/16 x 5/8 #605	520802	1
25	Retaining Ring	530244	2
26	"E" Retaining Ring	531002	1
27 (NS)	Label Serial Number	21314	1
28 (NS)	Label	CG-100328-3	1
29	Washer Compression #10 ZP	15177	2

Figure 16. CV2.6-H Assembly, P/N 205663 (page 2 of 2)

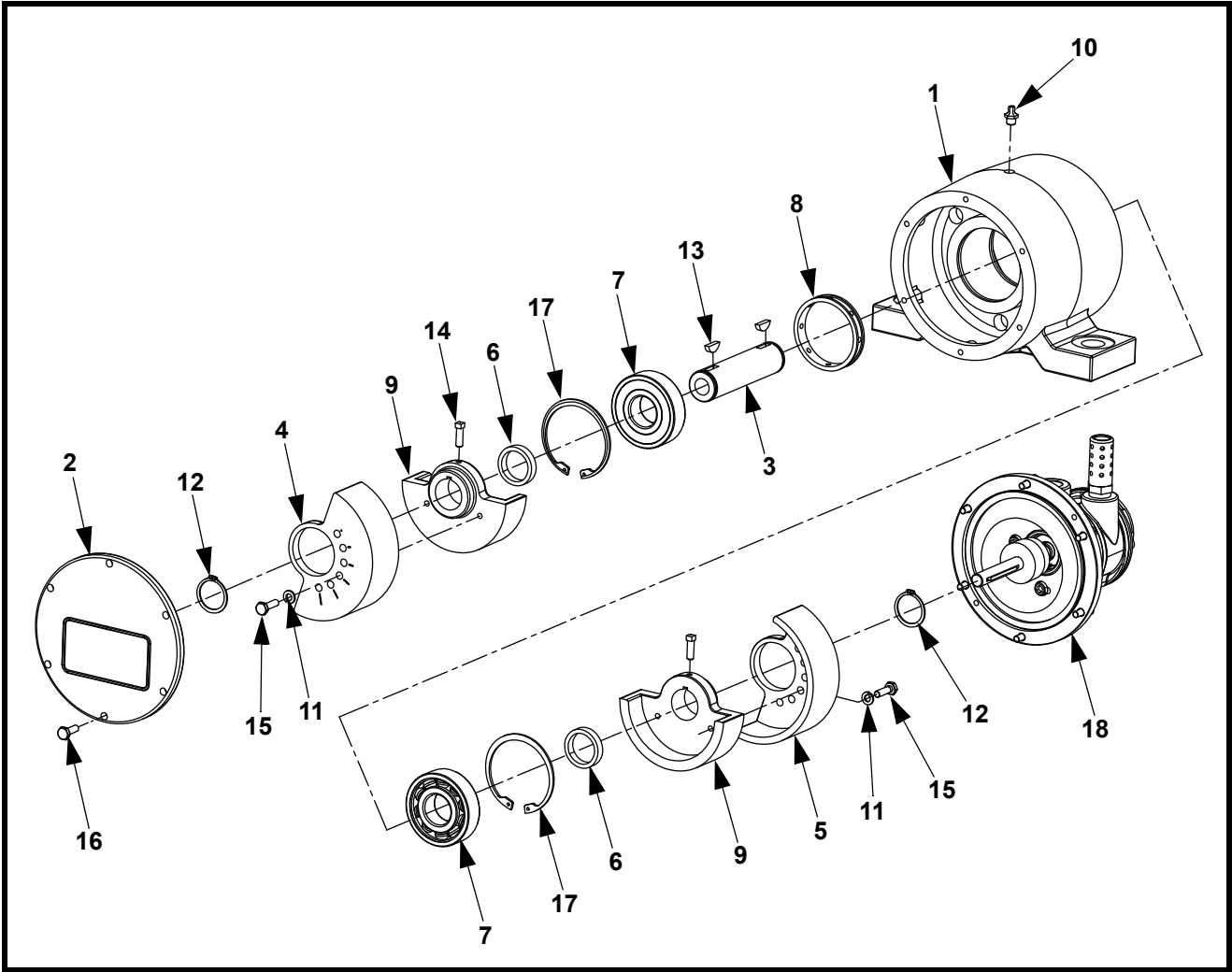

Figure 17. CV2.8 Case Assembly, P/N CV28-X-GC (page 1 of 2)

Item	Description	Part Number	Qty
1	Case	17497	1
2	Back Cover	17896	1
3	Eccentric Shaft	16417	1
4	Weight Eccentric Adjustable Left	29749-01	1
5	Weight Eccentric Adjustable Right	29749	1
6	Spacer	16352	2
7	Bearing	16070	2
8	Bearing Spacer	16354	1
9	Weight Eccentric Stationary	29744-02	2
10	Grease Fitting 1/8-27 NPT	11814	1
11	Washer Lock Helical Spring 1/4	CG-517798	2
12	Retaining Ring	16349	2
13	Key Woodruff 3/16 x 3/4 #606	16345	2
14	Screw Set SHCP 1/4-20NC x 3/4 ZP	11745-01	2
15	Screw HHC 1/4-20NC x 7/8	CG-500004	2
16	Screw HHC 1/4-20NC x 3/4	500003	6
17	Retaining Ring Internal	16071	2
18	Motor/Flange Assembly	Table V	1
19 (NS)	Air Motor Oil	14766	Table V
20 (NS)	Cap Lube Strap	12533	1
21 (NS)	Washer Compression 3/4	CG-517708	2
22 (NS)	Label Kit	33887	1

Figure 17. CV2.8 Case Assembly, P/N CV28-X-GC (page 2 of 2)

Table V. CV2.8 Case Assembly Part Numbers and Quantities

Part No.	Item 18 P/N	Item 19 Qty
CV28-A-GC	27873	1
CV28-H-GC	12959	0

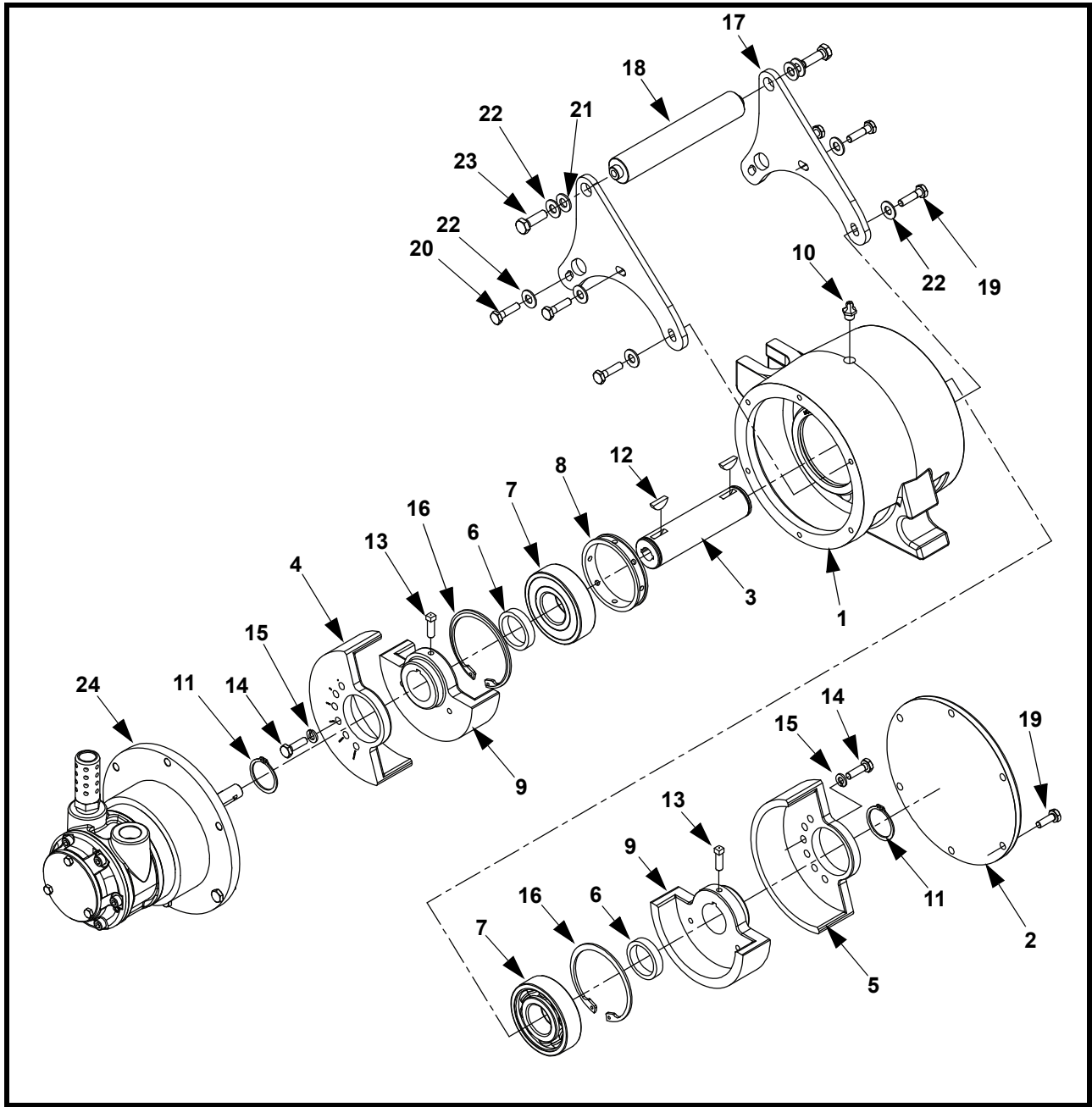

Figure 18. CC2.8 Case Assembly, P/N CC28-X-GC (page 1 of 2)

Item	Description	Part Number	Qty
1	Case	18030	1
2	Back Cover	17896	1
3	Eccentric Shaft	16417	1
4	Weight Eccentric Adjustable Right	29749	1
5	Weight Eccentric Adjustable Left	29749-01	1
6	Spacer	16352	2
7	Bearing	16070	2
8	Bearing Spacer	16354	1
9	Weight Eccentric Stationary	29744-02	2
10	Grease Fitting 1/8-27 NPT	11814	1
11	Retaining Ring Ext	16349	2
12	Key Woodruff 3/16 x 3/4 #606	16345	2
13	Screw Set SHCP 1/4-20NC x 3/4 ZP	11745-01	2
14	Screw HHC 1/4-20NC x 7/8	CG-500004	2
15	Washer Lock Helical Spring 1/4	CG-517798	2
16	Retaining Ring Internal	16071	2
17	Handle End Plate	18030-HEP	2
18	Extension Shaft	18030-H	1
19	Screw HHC 1/4-20NC (see Table VI for length)	Table VI	3
20	Screw HHC 1/4-20NC (see Table VI for length)	Table VI	3
21	Washer Flat 5/16	517226	2
22	Washer Belleville 5/16	CG-517694	8
23	Screw HHC 5/16-18NC x 1	CG-500041	2
24	Motor Assembly	Table VI	1
25 (NS)	Air Motor Oil	14766	Table VI
26 (NS)	Cap Lube Strap	12533	1
27 (NS)	Label Kit	33887	1

Figure 18. CC2.8 Case Assembly, P/N CC28-X-GC (page 2 of 2)

Table VI. CC2.8 Case Assembly Part Numbers and Quantities

Part No.	Item 19 P/N	Item 19 Length	Item 20 P/N	Item 20 Qty	Item 24 P/N	Item 25 Qty
CC28-A-GC	500005	1 in.	500005	1 in.	27873-CC2.8	1
CC28-H-GC	500003	3/4 in.	500007	1-1/4 in.	12959	0

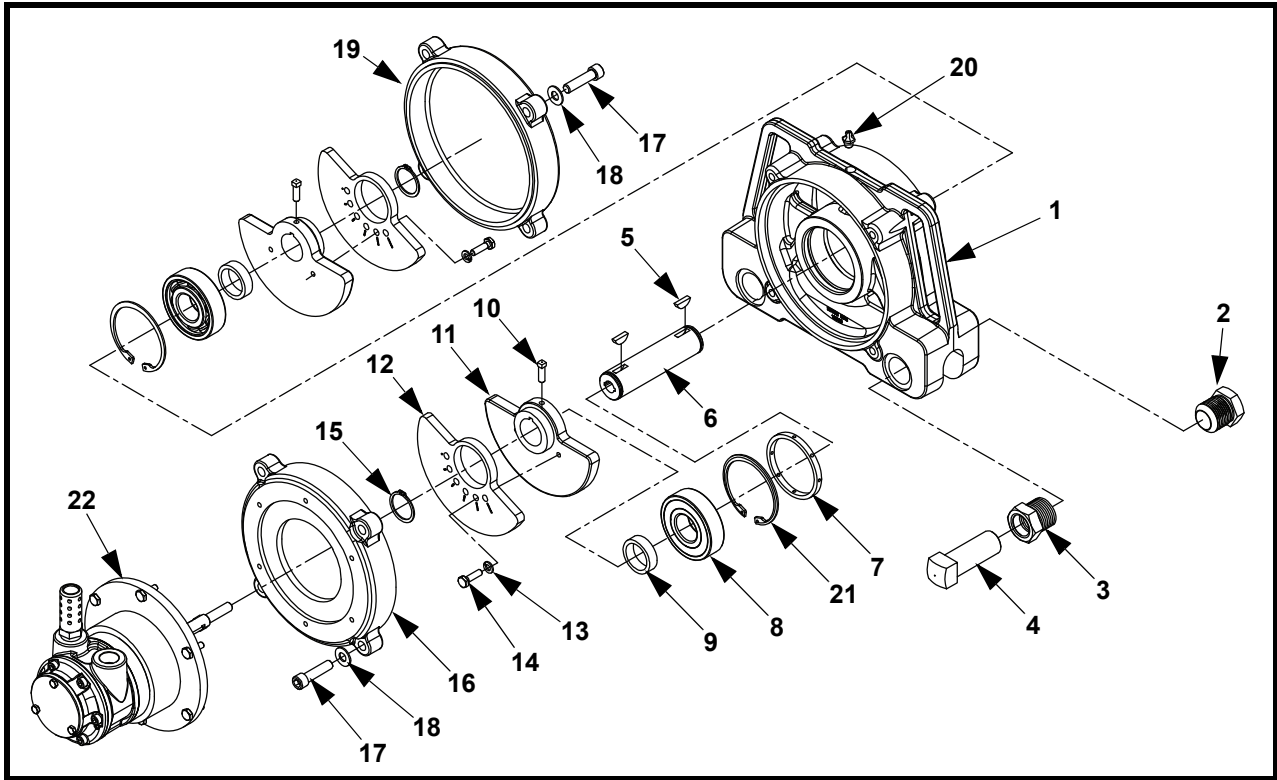

Figure 19. CCV4 Case Assembly, P/N CCV4-X-GC (page 1 of 2)

Item	Description	Part Number	Qty
1*	CCV4S/CCV4G Case	22068	1
2*	Static jaw	12719	2
3*	Clamp block bushing	12257	2
4*	Screw Set HHCP 1-12NF x 2-1/2	31318-01	2
5	Key Woodruff 3/16 x 3/4 #606	16345	2
6	Eccentric shaft	16417	1
7	Bearing spacer	22067	1
8	Bearing	16070	2
9	Eccentric spacer	31659	2
10	Screw Set SHCP 1/4-20NC x 3/4 ZP	11745-01	2
11	Weight Eccentric Stationary	29747-01	2
12	Weight eccentric adjustable	29748	2
13	Washer lock helical spring 1/4 reg ZP	CG-517798	2
14	Screw HHC 1/4-20NC x 7/8 Gr5 ZP	CG-500004	2
15	Retaining ring Ext	16349	2
16	Motor side case flange	16061	1
17	Screw SHC 3/8-16NC x 1-1/2	501277	8
18	Washer Belleville 3/8 ZP	CG-517696	8
19	Back cover	16063	1
20	Fitting grease 1/8-27 NPT	11814	1
21	Retaining Ring Internal	16071	2
22	Motor Assembly	Table VII	1
23 (NS)	Air Motor Oil	14766	Table VII

*Included in CCV4 case assembly 22777

Figure 19. CCV4 Case Assembly, P/N CCV4-X-GC (page 2 of 2)

Table VII. CCV4 Case Assembly Part Numbers and Quantities

Part No.	Item 22 P/N	Item 23 Qty
CCV4-A-GC	27873-CCV4	1
CCV4-H-GC	12959	0

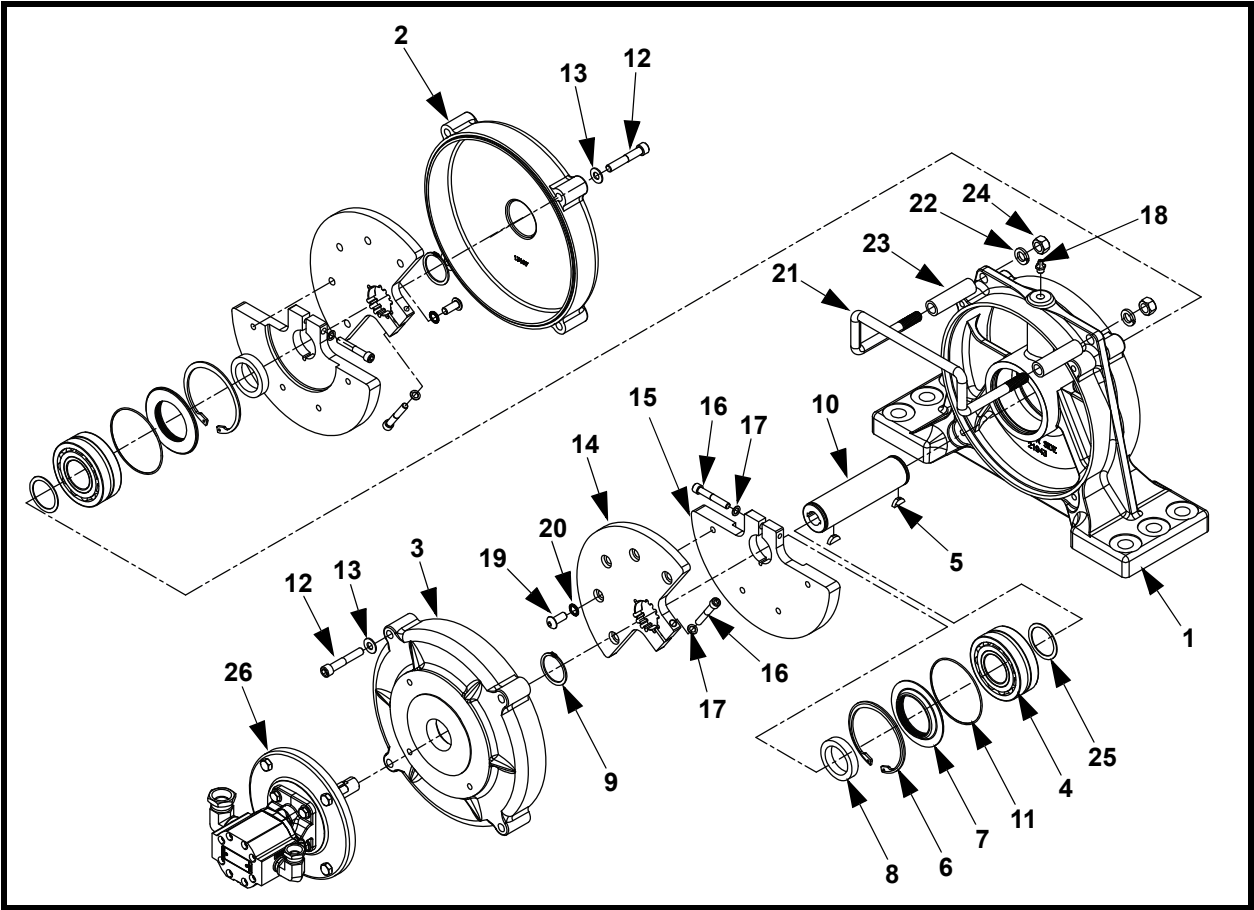

Figure 20. DV6 Case Assembly, P/N DV6-X-GC (page 1 of 2)

Item	Description	Part Number	Qty
1	DV6 Case	22092	1
2	Back Cover	13168	1
3	Motor Flange	13166	1
4	Bearing	24021	2
5	Key Woodruff 3/16 x 3/4	16345	2
6	Retaining Ring Internal	22230	2
7	Seal Retainer	25768-G	2
8	Eccentric Spacer	31660	2
9	Retaining Ring External	12569	2
10	Eccentric Shaft	22090	1
11	O-ring #043	22084	2
12	Screw SHC 3/8-16NC-3A x 2-1/4	13256	8
13	Washer Belleville 3/8	CG-517696	8
14	Weight Eccentric Adjustable	34656	2
15	Weight Eccentric Fixed	34655	2
16	Screw SHC 5/16-18NC-3A x 2	SUS10061	4
17	Washer Schnorr D8	513004	4
18	Fitting Grease	11814	1
19	Screw HSBHC 3/8-16NC x 7/8	SUS10062	2
20	Washer Schnorr D10	513005	2
21	Handle	10344	1
22	Washer Lock Helical Spring 1/2	517802	2
23	Bushing Handle	13255	2
24	Nut Hex 1/2-13NC	11771	2
25	Washer Shim Ring M40	SUS10060	2
26	Motor Assembly	Table VIII	1
27 (NS)	Air Motor Oil	14766	Table VIII
28 (NS)	Cap Lube Strap	12533	1
29 (NS)	Label Kit	33887	1

Figure 20. DV6 Case Assembly, P/N DV6-X-GC (page 2 of 2)

Table VIII. DV6 Case Assembly Part Numbers and Quantities

Part No.	Item 26 P/N	Item 27 Qty
DV6-A-GC	27874	1
DV6-H-GC	12965	0

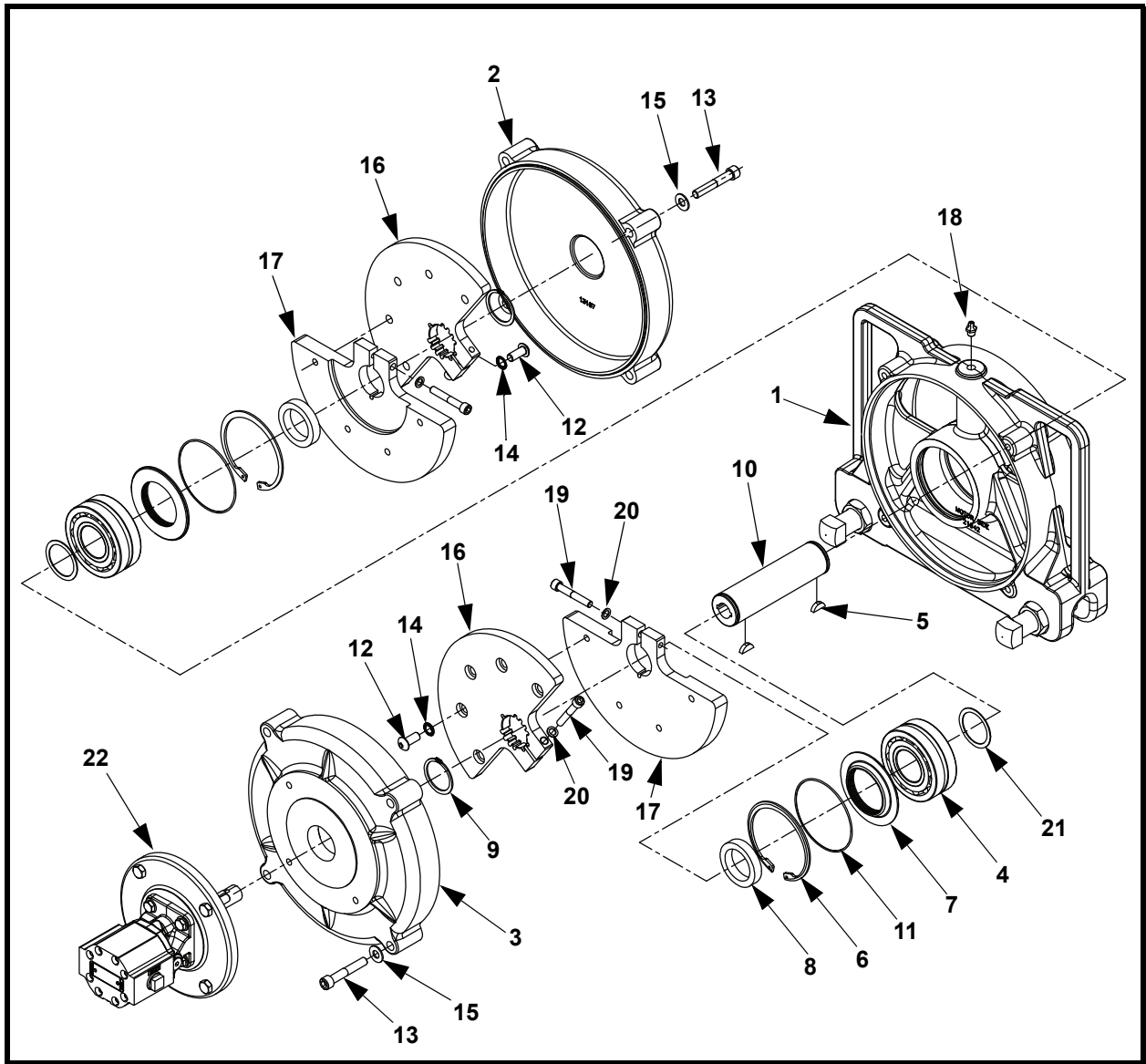

Figure 21. CCV6 Case Assembly, P/N CCV6-X-GC (page 1 of 2)

Item	Description	Part Number	Qty
1	CCV6S Case	22776	1
2	Back Cover	13168	1
3	Motor Flange	13166	1
4	Bearing Spherical Roller	24021	2
5	Key Woodruff 3/16 x 3/4	16345	2
6	Retaining Ring Internal BEV 3.625	22230	2
7	Seal Retainer	25768-G	2
8	Eccentric Spacer	31660	2
9	Retaining Ring Ext Std 1.5625 Dia.	12569	2
10	Eccentric Shaft	22090	1
11	O-ring #043	22084	2
12	Screw HSBHC 3/8-16NC x 7/8	SUS10062	2
13	Screw SHC 3/8-16NC-3A x 2-1/4	13256	8
14	Washer Schnorr D10	513005	2
15	Washer Belleville 3/8	CG-517696	8
16	Weight Eccentric Adjustable	34656	2
17	Weight Eccentric Fixed	34655	2
18	Fitting Grease 1/8-27 NPT	11814	1
19	Screw SHC 5/16-18NC-3A x 2	SUS10061	4
20	Washer Schnorr D8	513004	4
21	Washer Shim Ring M40	SUS10060	2
22	Motor Assembly	Table IX	1
23 (NS)	Air Motor Oil	14766	Table IX
24 (NS)	Cap Lube Strap	12533	1
25 (NS)	Label Kit	33887	1

Figure 21. CCV6 Case Assembly, P/N CCV6-X-GC (page 2 of 2)

Table IX. CCV6 Case Assembly Part Numbers and Quantities

Part No.	Item 22 P/N	Item 23 Qty
CCV6-A-GC	27874	1
CCV6-H-GC	12965	0





Figure 22. Air Motor Caution Label

Appendix

Brute® Vibrator technical data



Appendix

Table A-I. Brute® Hydraulic Vibrator Specifications^a

Model	Eccentric Setting	Unbalance in-lb (cm-kg)	Required psi (bar) to start	Max PSI	rpm	gpm (L/s) ^b	Force lb (kg)	rpm	gpm (L/s) ^b	Force lb (kg)	rpm	gpm (L/s) ^b	Force lb (kg)	rpm	gpm (L/s) ^b	Force lb (kg)	Max. lb (kg) Material in Slope Portion ^c
CV2.02-H (205692)	e	0.22 (.25)	-	1500	4000	2.8 (.18)	100 (45)	6000	4.2 (.26)	225 (102)	7500	5.3 (.33)	351 (159)	9000	6.3 (.40)	506 (230)	5000 (2273)
	1	0.35 (.40)	-	1500	4000	2.8 (.18)	159 (72)	6000	4.2 (.26)	358 (162)	7000	4.9 (.31)	487 (221)	9000	6.3 (.40)	805 (365)	
	2 ^d	0.48 (.55)	-	1500	4000	2.8 (.18)	218 (99)	6000	4.2 (.26)	491 (223)	7000	4.9 (.31)	668 (303)	9000	6.3 (.40)	1104 (501)	
	3	0.52 (.60)	-	1500	4000	2.8 (.18)	236 (107)	6000	4.2 (.26)	532 (241)	7000	4.9 (.31)	724 (328)	9000	6.3 (.40)	1196 (542)	16,000 (7272)
	4	0.61 (.70)	-	1500	4000	2.8 (.18)	277 (126)	6000	4.2 (.26)	624 (283)	7000	4.9 (.31)	849 (385)	9000	6.3 (.40)	1403 (636)	
CV2.6-H (205663)	5	0.69 (.79)	-	1500	4000	2.8 (.18)	314 (142)	6000	4.2 (.26)	705 (320)	7000	4.9 (.31)	960 (435)	9000	6.3 (.40)	1587 (720)	
	1	2.00 (2.30)	-	1500	1500	1.0 (.07)	128 (58)	2500	1.7 (.11)	355 (161)	3500	2.4 (.15)	696 (316)	5000	3.5 (.22)	1420 (644)	
	2 ^d	2.40 (2.77)	-	1500	1500	1.0 (.07)	153 (69)	2500	1.7 (.11)	426 (193)	3500	2.4 (.15)	835 (379)	5000	3.5 (.22)	1704 (773)	
	3	2.90 (3.34)	-	1500	1500	1.0 (.07)	185 (84)	2500	1.7 (.11)	515 (234)	3500	2.4 (.15)	1009 (458)	5000	3.5 (.22)	2059 (934)	
	4	3.40 (3.92)	-	1500	1500	1.0 (.07)	217 (98)	2500	1.7 (.11)	604 (274)	3500	2.4 (.15)	1183 (537)	5000	3.5 (.22)	2414 (1095)	33,000 (15,000)
CC2.8-H (CC28-H-GC)	5	3.90 (4.49)	-	1500	1500	1.0 (.07)	249 (113)	2500	1.7 (.11)	692 (314)	3500	2.4 (.15)	1357 (616)	5000	3.5 (.22)	2769 (1256)	
	6	4.40 (5.07)	-	1500	1500	1.0 (.07)	281 (127)	2500	1.7 (.11)	781 (354)	3500	2.4 (.15)	1531 (694)	5000	3.5 (.22)	3124 (1417)	
	7	5.70 (6.57)	-	1500	1500	1.0 (.07)	364 (165)	2500	1.7 (.11)	1012 (459)	3500	2.4 (.15)	1983 (899)	4500	3.5 (.22)	3278 (1487)	
	1	8.0 (9.2)	180 (12)	1500	3000	4.35 (0.27)	2050 (930)	3500	5.08 (0.32)	2775 (1259)	4000	5.8 (0.37)	3625 (1644)	4600	6.67 (0.42)	4800 (2177)	
	2	7.0 (8.1)	160 (11)	1500	3000	4.35 (0.27)	1800 (816)	3500	5.08 (0.32)	2425 (1100)	4000	5.8 (0.37)	3175 (1440)	4600	6.67 (0.42)	4200 (1905)	
	3	6.0 (6.9)	140 (10)	1500	3000	4.35 (0.27)	1525 (692)	3500	5.08 (0.32)	2100 (953)	4000	5.8 (0.37)	2725 (1236)	4600	6.67 (0.42)	3600 (1633)	50,000 (22,680)
	4 ^d	4.5 (5.2)	125 (9)	1500	3000	4.35 (0.27)	1150 (522)	3500	5.08 (0.32)	1550 (703)	4000	5.8 (0.37)	2050 (930)	4600	6.67 (0.42)	2700 (1225)	
CV2.8-H (CV28-H-GC)	5	3.0 (3.5)	125 (9)	1500	3000	4.35 (0.27)	750 (340)	3500	5.08 (0.32)	1050 (476)	4000	5.8 (0.37)	1350 (612)	4600	6.67 (0.42)	1800 (816)	
	6	2.0 (2.3)	100 (7)	1500	3000	4.35 (0.27)	500 (227)	3500	5.08 (0.32)	700 (318)	4000	5.8 (0.37)	900 (408)	4600	6.67 (0.42)	1200 (544)	
	1	8.0 (9.2)	180 (12)	1500	3000	4.35 (0.27)	2050 (930)	3500	5.08 (0.32)	2775 (1259)	4000	5.8 (0.37)	3625 (1644)	4600	6.67 (0.42)	4800 (2177)	
	2 ^d	7.0 (8.1)	160 (11)	1500	3000	4.35 (0.27)	1800 (816)	3500	5.08 (0.32)	2425 (1100)	4000	5.8 (0.37)	3175 (1440)	4600	6.67 (0.42)	4200 (1905)	
	3	6.0 (6.9)	140 (10)	1500	3000	4.35 (0.27)	1525 (692)	3500	5.08 (0.32)	2100 (953)	4000	5.8 (0.37)	2725 (1236)	4600	6.67 (0.42)	3600 (1633)	95,000 (43,092)
	4	5.0 (5.8)	125 (9)	1500	3000	4.35 (0.27)	1275 (578)	3500	5.08 (0.32)	1750 (794)	4000	5.8 (0.37)	2275 (1032)	4600	6.67 (0.42)	3005 (1363)	
CCV4-H (CCV4-H-GC)	5	3.5 (4.0)	125 (9)	1500	3000	4.35 (0.27)	900 (408)	3500	5.08 (0.32)	1200 (544)	4000	5.8 (0.37)	1600 (726)	4600	6.67 (0.42)	2103 (954)	
	6	2.5 (2.9)	100 (7)	1500	3000	4.35 (0.27)	650 (295)	3500	5.08 (0.32)	870 (395)	4000	5.8 (0.37)	1125 (510)	4600	6.67 (0.42)	1502 (681)	
	1	50 (57.6)	150 (10)	1200	2100	7.1 (0.45)	6250 (2835)	2400	8.2 (0.51)	8175 (3708)	2700	9.2 (0.58)	10,350 (4695)	3000	10.2 (0.64)	12,800 (5806)	
	2	44 (50.4)	145 (10)	1200	2100	7.1 (0.45)	5500 (2495)	2400	8.2 (0.51)	7150 (3243)	2700	9.2 (0.58)	9050 (4105)	3000	10.2 (0.64)	11,200 (5080)	
	3	38 (43.2)	135 (10)	1200	2100	7.1 (0.45)	4700 (2132)	2400	8.2 (0.51)	6150 (2790)	2700	9.2 (0.58)	7750 (3515)	3000	10.2 (0.64)	9600 (4354)	400,000 (181,440)
	4	31 (36.0)	130 (9)	1200	2100	7.1 (0.45)	3900 (1769)	2400	8.2 (0.51)	5125 (2325)	2700	9.2 (0.58)	6475 (2937)	3000	10.2 (0.64)	9202 (4174)	
CCV6-H (CCV6-H-GC)	5 ^d	25 (28.8)	125 (9)	1200	2100	7.1 (0.45)	3125 (1417)	2400	8.2 (0.51)	4100 (1860)	2700	9.2 (0.58)	5175 (2347)	3000	10.2 (0.64)	6400 (2903)	
	6	12 (13.8)	110 (7)	1200	2100	7.1 (0.45)	1500 (680)	2400	8.2 (0.51)	1975 (896)	2700	9.2 (0.58)	2475 (1123)	3000	10.2 (0.64)	3050 (1383)	

Martin Engineering M3193-08/23

A-2

Brute® Vibrators

^a Data from vibrator mounted to 10,000-lb test block. Frequency and force output will decrease on less rigid mount.

^b Per single unit measured at the inlet on the motor.

^c Rule of thumb: 1 lb (0.45 kg) vibrator force for each 10 lb (4.5 kg) of bin content. Reinforce mount area to prevent flexing of walls.

^d Normal factory setting.

^e Stationary weight.



Table A-II. Brute® Pneumatic Vibrator Specifications^a

Model	Eccentric Setting	Unbalance in-lb (cm-kg)	40 psi (2.8 bar, 0.28 MPa)			60 psi (4.1 bar, 0.41 MPa)			80 psi (5.5 bar, 0.55 MPa)			Max. lb (kg) Material in Slope Portion ^c
			rpm	cfm L/s ^b	Force lb (kg)	rpm	cfm L/s ^b	Force lb (kg)	rpm	cfm L/s ^b	Force lb (kg)	
CC2.8-A (CC28-A-GC)	1	8.0 (9.2)	3600	39 (18)	3020 (1370)	4300	52 (25)	4320 (1960)	4700	59 (28)	5145 (2334)	50,000 (22,680)
	2	7.0 (8.1)	3600	48 (23)	2650 (1202)	4300	50 (24)	3780 (1715)	4700	58 (27)	4520 (2050)	
	3	6.0 (6.9)	3700	40 (19)	2335 (1059)	4400	51 (24)	3300 (1497)	4800	60 (28)	3930 (1783)	
	4 ^d	4.5 (5.2)	3800	38 (18)	1890 (857)	4600	51 (24)	2765 (1254)	5000	63 (30)	3270 (1483)	
	5	3.0 (3.5)	3900	37 (17)	1385 (628)	4600	49 (23)	1925 (873)	5100	64 (30)	2365 (1073)	
	6	2.0 (2.3)	4000	37 (17)	910 (413)	4700	53 (25)	1255 (569)	5300	66 (31)	1600 (726)	
CCV4-A (CCV4-A-GC)	1	8.0 (9.2)	3300	38 (18)	2500 (1134)	4200	51 (24)	4000 (1814)	4700	58 (27)	5100 (2313)	80,000 (36,288)
	2 ^d	7.0 (8.1)	3400	37 (17)	2400 (1089)	4200	50 (24)	3500 (1588)	4700	56 (26)	4400 (1996)	
	3	6.0 (6.9)	3600	38 (18)	2300 (1043)	4400	49 (23)	3300 (1497)	4900	59 (28)	4100 (1860)	
	4	5.0 (5.8)	3700	37 (17)	2100 (953)	4600	50 (24)	2800 (1270)	5000	62 (29)	3300 (1497)	
	5	3.5 (4.0)	4000	36 (17)	1900 (862)	4730	48 (23)	2200 (998)	5200	63 (30)	2700 (1225)	
	6	2.5 (2.9)	4100	37 (17)	1500 (680)	4840	52 (25)	1700 (771)	5500	65 (31)	1900 (862)	
CCV6-A (CCV6-A-GC)	1	50.0 (57.6)	2000	38 (18)	5680 (2576)	2200	44 (21)	6873 (3118)	2600	84 (40)	9605 (4357)	500,000 (226,800)
	2	43.8 (50.4)	2200	42 (20)	6014 (2728)	2400	47 (22)	7157 (3246)	2750	85 (40)	9396 (4262)	
	3	37.5 (43.2)	2400	46 (22)	6134 (2782)	2600	50 (24)	7199 (3265)	2900	85 (40)	8957 (4063)	
	4	31.3 (36.0)	2600	50 (24)	6000 (2722)	2800	53 (25)	6958 (3156)	3100	86 (41)	8529 (3869)	
DV6-A (DV6-A-GC)	5 ^d	25.0 (28.8)	2750	53 (25)	5369 (2435)	3000	56 (26)	6390 (2898)	3400	86 (41)	8208 (3723)	
	6	12.0 (13.8)	3000	51 (24)	3067 (1391)	3200	58 (27)	3490 (1583)	3500	65 (31)	4175 (1894)	

^a Data from vibrator mounted to 10,000-lb test block. Frequency and force output will decrease on less rigid mount.

^b Per single unit measured at the inlet on the motor.

^c Rule of thumb: 1 lb (0.45 kg) vibrator force for each 10 lb (4.5 kg) of bin content. Reinforce mount area to prevent flexing of walls.

^d Normal factory setting.

^e Stationary weight.



Notes



Any product, process, or technology described here may be the subject of intellectual property rights reserved by Martin Engineering Company. Trademarks or service marks designated with the ® symbol are registered with the U.S. Patent and Trademark Office and may be proprietary in one or more countries or regions. Other trademarks and service marks belonging to Martin Engineering Company in the United States and/or other countries or regions may be designated with the “TM” and “SM” symbols. Brands, trademarks, and names of other parties, who may or may not be affiliated with, connected to, or endorsed by Martin Engineering Company, are identified wherever possible. Additional information regarding Martin Engineering Company’s intellectual property can be obtained at www.martin-eng.com/trademarks.

AIRMATIC INC

airmatic.com | 215.333.5600 | infocenter@airmatic.com

