

Silver Sonic Turbine®

Operating Instructions

Global® External
Turbine Vibrators

MODELS: SST-12
SST-16
SST-25
SST-35



Table of Contents	Page
I. Introduction	2
Safety Precautions	
II. Installation Procedures	3
III. Mounting Locations	4 - 5
IV. Operation	5
Air Requirements	
V. Turbine Vibrator Performance	6
VI. Trouble Shooting	6
VII. Dimensions	7
VIII. Parts Explosion for the SST-12, SST-16, and SST-25	8
IX. Parts List for the SST-12, SST-16, and SST-25	8
X. Parts Explosion for the SST-35	9
XI. Parts List for the SST-35	9
XII. Assembly & Disassembly for the SST-12, SST-16, and SST-25	10 - 11
XIII. Assembly & Disassembly for the SST-35	12 - 13

I. Introduction

For optimum performance, cycle the vibrator on and off. The vibrator acts as a friction reducer and once the bulk solid is set into motion, gravity should do the rest. Do not operate the vibrator on an empty hopper as this may cause structural damage to the hopper.

Vibrators should be operated only when discharge gates are open. Operating the vibrator with the discharge gate closed will cause the material inside the structure to compact.

Vibration has two important elements – Frequency and Amplitude. Frequency is the speed (RPM) or the number of vibrations per minute. It is controlled by the oil flow to a hydraulic vibrator or the air flow to a pneumatic vibrator. Amplitude is the unbalance or the amount of eccentric weight. The faster the eccentric weights turn the more force output generated. Force and frequency work together. It is not necessary to use a lot of force when you have the frequency.

Safety Precautions

- Follow all mounting instructions.
- Do not operate vibrators when structure is empty.
- Do not operate vibrators when gate is closed or conveyor is stopped unless consolidation of material is desired.
- Wear ear protection for 90+ decibel levels.
- Do not operate vibrators without side cap.
- Normal operating range is 20 to 80 P.S.I. (1.36 to 5.44 Bar).
- Disconnect airline before maintenance or repair.

II. Installation Procedures

Caution!

Do not mount the vibrator directly to the structure wall. Use a channel iron stiffener for proper mount rigidity and as the transducer of the vibrational energy.

The key to successful vibration is the correct mounting procedure. Rotary vibration resonates the material inside the structure when the vibrator is mounted correctly. The vibrator should appear motionless. There should not be a large amount of motion or noise.

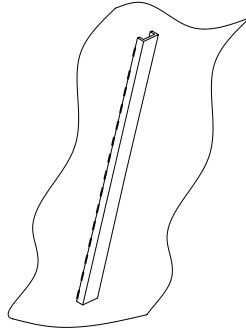

Attach the vibrator to the channel iron. Stitch weld bolts to the back of the channel iron or the channel iron may be drilled and tapped to accept the mounting bolts. An alternate method is to cut a second channel iron slightly longer than the footprint of the vibrator. Stitch weld the second channel iron to the first. Do not weld the ends. Mount the vibrator to the second channel iron.

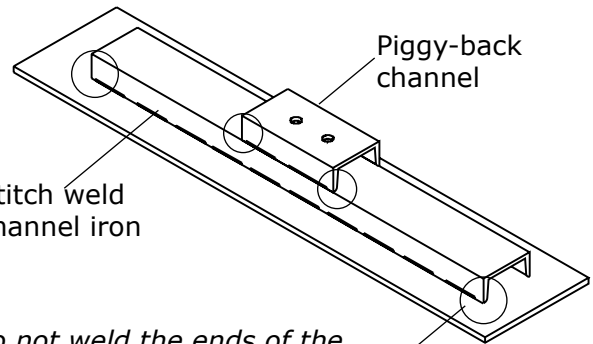

Do not weld the ends of the channel iron - this allows the vibrational force to "escape". Solid welded ends trap the force which can cause stress cracks.

Channel Irons - Size & Mounting

Important!

The channel iron should be at least two-thirds of the height of the sloped portion of the hopper but no greater than 5 feet (1.5 m).

The channel iron should be at least two-thirds the height of the sloped portion of the hopper, but not less than the length specified in chart below. The channel iron width should not be less than the base width of the vibrator. See chart below for recommended channel sizes. DO NOT install more than one vibrator on the same channel iron or use a channel iron shorter than the recommended length. A short channel may flex the bin wall.

Stitch weld the channel iron vertically to the slope portion of the bin wall. Weld 3 inches (7.5 cm), skip 1 inch (2.5 cm), weld 3 inches (7.5 cm), etc... Leave 1 inch (2.5 cm) un-welded on the ends and corners. This allows the vibration to dissipate out the ends of channel without causing stress cracks to the hopper or bin. By doing so, should the weld fail, the entire mount will not fall off. Do not mount the channel iron horizontally.

Channel Iron Size:

MODEL	CHANNEL SIZE	CHANNEL LENGTH	MOUNT BOLT TORQUE
SST-12	2 X 1 X 3/16	24	6 FT-LB
SST-16	3 x 4.1	36	25 FT-LB
SST-25	3 X 4.1	48	62 FT-LB
SST-35	4 X 5.4	60	62 FT-LB

Secure the vibrator to the channel iron with the fasteners that shipped with the Turbine vibrator. Use lock washers or an adhesive such as Loctite® 262. Tighten in a sequential process the socket head cap screws to the torque stated in chart on the left. At least two passes are required in most situations. Give all screws the same torque value. Grade 8 screws can handle more torque than standard screws. If Loctite® is not used, retorque the screw after the vibrator has operated for a few minutes and check tightness often. If Loctite® is used do not retorque the bolts as this will break the Loctite® bond.

III. Mounting Locations

Single Vibrator

Install a channel iron stiffener on the outside of the sloping wall 1/3 the distance above the discharge opening.

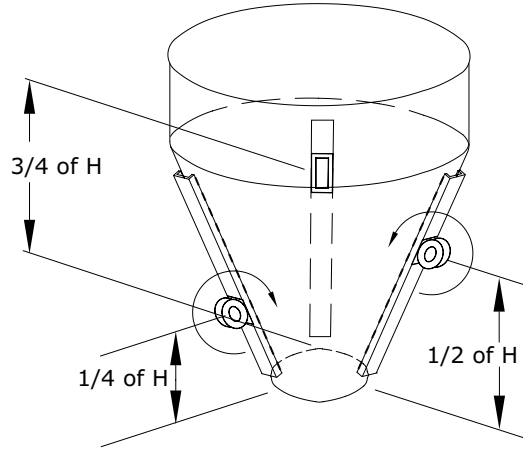
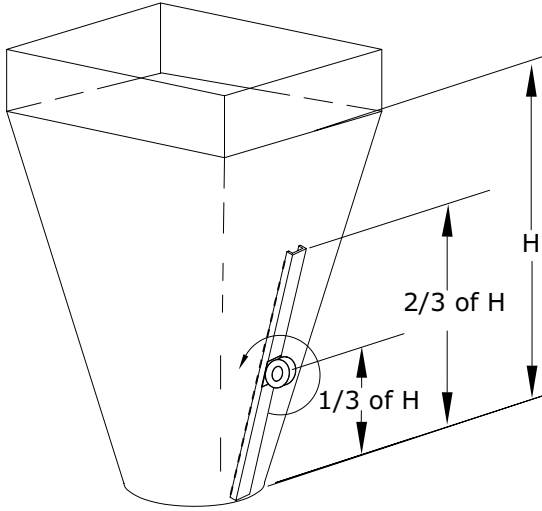

Three Vibrators

Install channel iron stiffeners mounted 120° apart. Install the first vibrator on the outside of the sloping wall 1/4 the distance above the discharge opening. Install the second vibrator on a separate channel iron at 1/2 the distance above the discharge opening. Install the third vibrator on the remaining channel iron at 3/4 the distance above the discharge opening.

Multiple Vibrators

Use more than one vibrator when the diameter or width of any wall is greater than 12 feet (3.66 m). Always mount the vibrators on different planes.

Two Vibrators on Round or Square Hoppers

Install channel iron stiffeners 180° apart. Install one vibrator on the outside of the sloping wall 1/3 the distance above the discharge opening. Install the second vibrator on the outside of the opposite sloping wall 2/3 the distance above the discharge opening.

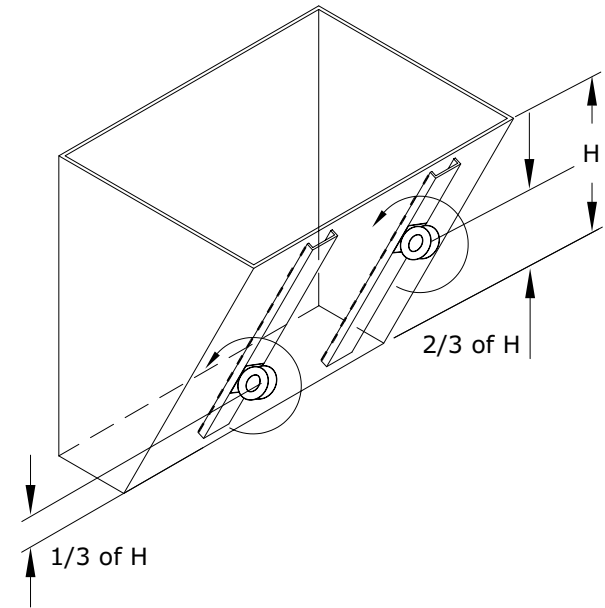
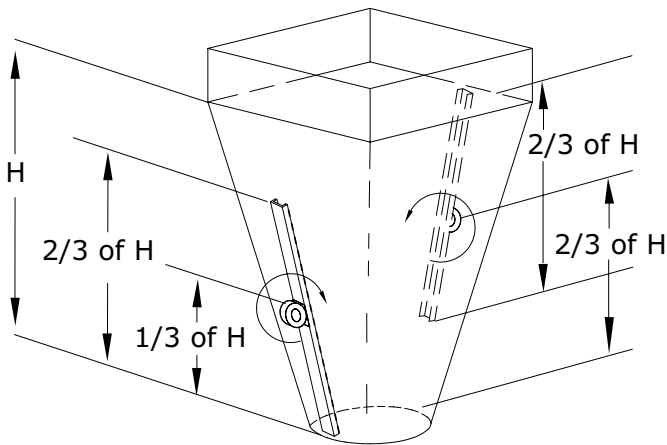

Two Vibrators on Rectangular Hoppers

Install channel iron stiffeners on opposite sides of the long walls. Install one vibrator on the outside of the sloping wall 1/3 the distance from the discharge opening. Install the second vibrator on the outside of the opposite sloping wall 2/3 the distance above the discharge opening. When only one wall slopes, mount both stiffeners on it. Equally space the stiffeners on the wall. Place one vibrator 1/3 above the discharge opening on one channel iron and the other vibrator 2/3 above the bin's discharge opening on the second channel.

Installation on Chutes and Flow Pipes

Mount channel iron stiffeners vertically or in the direction of material flow. Center the channel if the chute is less than 6 feet (1.83 m) in width. If the chute is greater than 6 feet in width, use two vibrators on separate channel irons. To maximize each vibrator's radius of influence; center each channel iron in each half of the chute. Each channel iron should be located $\frac{1}{4}$ of the chute width from the edge and $\frac{1}{2}$ of the chute width apart. (e.g. – for a chute 8' wide, the channel iron locations would be 2' from each edge and 4' apart.) When wall thickness is less than $\frac{1}{8}$ ", additional reinforcement may be required.

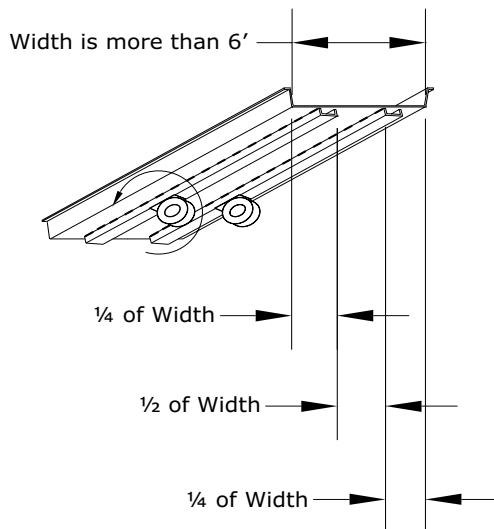

Placement on Channel Iron

The axis of rotation of the eccentric weights for all rotary vibrators should be oriented in the direction of material flow. The shaft of the vibrator should ideally be in a horizontal position to prolong bearing life.

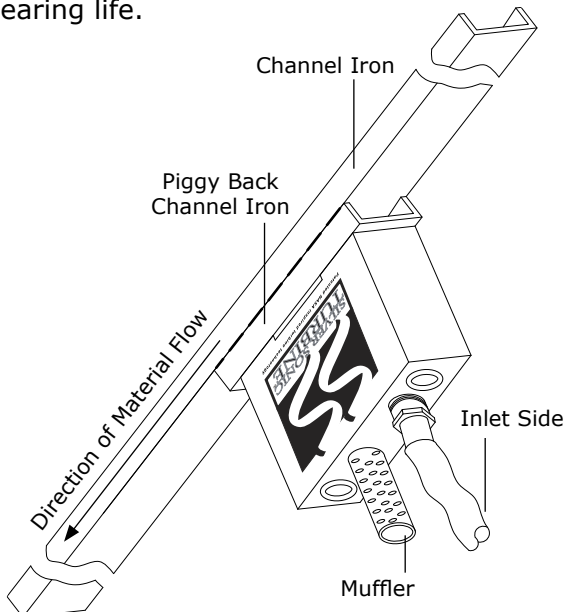

IV. Operation

Air Requirements

Important!

DO NOT LUBRICATE!

Lubrication is not required and will decrease vibrator performance.

Operate on filtered, (20 to 40 micron) regulated air between 20 and 80 P.S.I. (1.36 to 5.44 Bar). DO NOT use lubricated air. Lubricated air will decrease vibrator performance or cause the vibrator to stop. An air regulator may be used to control the vibrator speed. Adjust airflow until material flow occurs. More air is not always better. Operating the vibrator at higher pressures will reduce bearing life. (See performance data table on page 6). Speed variations are normal in the first few minutes of the initial run (approximately 3-5 minutes at 40 psi).

Cycle the vibrator on and off. Turbine vibrators can run continuously, but it is usually not necessary. Once the material is set into motion, gravity should do the rest. Do not operate the vibrator on an empty hopper.

V. Turbine Vibrator Performance

PERFORMANCE DATA FOR SILVER SONIC TURBINE® VIBRATORS																						
VIBRATOR MODEL	UN-BALANCE		AIR PRESSURE																			
			20 PSI (1.4 BAR)					40 PSI (2.8 BAR)					60 PSI (4.1 BAR)					80 PSI (5.5 BAR)				
			SPEED		FLOW		FORCE	SPEED		FLOW		FORCE	SPEED		FLOW		FORCE	SPEED		FLOW		FORCE
	LB-IN	KG-MM	RPM	CFM	LPM	LBS	N	RPM	CFM	LPM	LBS	N	RPM	CFM	LPM	LBS	N	RPM	CFM	LPM	LBS	N
SST-12	0.006	0.69	24,500	< 1	29	102	454	32,000	1.4	40	174	773	36,000	1.8	51	220	979	40,000	2.1	59	272	1210
SST-16	0.017	1.96	18,100	1.3	36	160	712	23,550	1.6	46	270	1201	27,230	1.9	54	360	1601	30,000	2.2	62	440	1960
SST-25	0.098	11.29	12,200	5.4	96	415	1846	15,100	5.0	144	630	2802	17,600	8.5	240	860	3825	19,000	11.5	324	1000	4450
SST-35	0.273	31.45	7,500	6.8	193	436	1940	10,900	10.0	283	921	4098	13,000	15.0	425	1310	5828	15,500	20.0	566	1863	8286
5 PSI (.34 BAR) required for start-up.																						
All turbine vibrators ship complete with muffler and fasteners.																						

VI. Troubleshooting Guide

PROBLEM	PROBABLE CAUSE	SOLUTION
Vibrator runs slowly. OR Vibrator does not operate.	Airline is restricted. OR the airline is connected to vibrator exhaust port.	Check for faulty connections, kinked or clogged airline.
	Inadequate air supply.	Check in line filter. Use airline equal to or larger than the vibrator inlet port. Check compressor.
	Contamination in vibrator, airline, muffler, or air filter.	Disassemble and clean vibrator. Blow out airline. Check airline filter.
	Improper reassembly after cleaning.	Check rotor placement. Make sure turbine slots face the inlet jet.
Vibrator makes excessive noise.	Mounting is not rigid.	Check for loose bolts, broken welds, signs of separation, or fatigue in structure.
	Muffler not used.	Install the muffler.
	Structure is empty.	Turn off vibrator.

VII. Dimensions

VIBRATOR	A	B	C	D	MOUNT HOLE DIAMETER	PORT DIAMETER	WEIGHT
	in	in	in	in	in	in	lb
	mm	mm	mm	mm	mm		kg
SST-12	2.50	2.00	1.25	1.938	5/16	1/8 NPT	0.7
	63.5	50.8	31.75	49.22	8		.32
SST-16	3.25	2.50	1.62	2.563	7/16	1/4 NPT	1.5
	82.55	63.5	41.19	65.10	11		.68
SST-25	5.00	4.00	2.50	3.875	5/8	3/8 NPT	5.3
	127	101.6	63.5	98.42	16		2.4
SST-35	6.5	5.00	2.50	5.375	17/32	3/8 NPT inlet	8.5
	165.1	127	63.5	136.52	13.5	1/2 NPT outlet	3.85

Top View

Side View

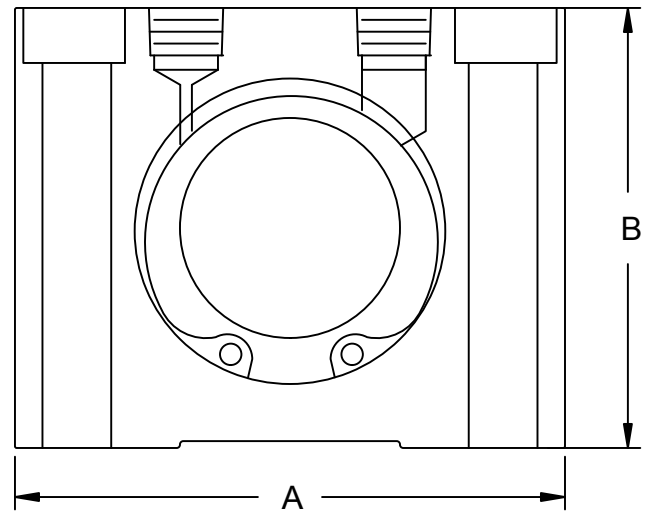
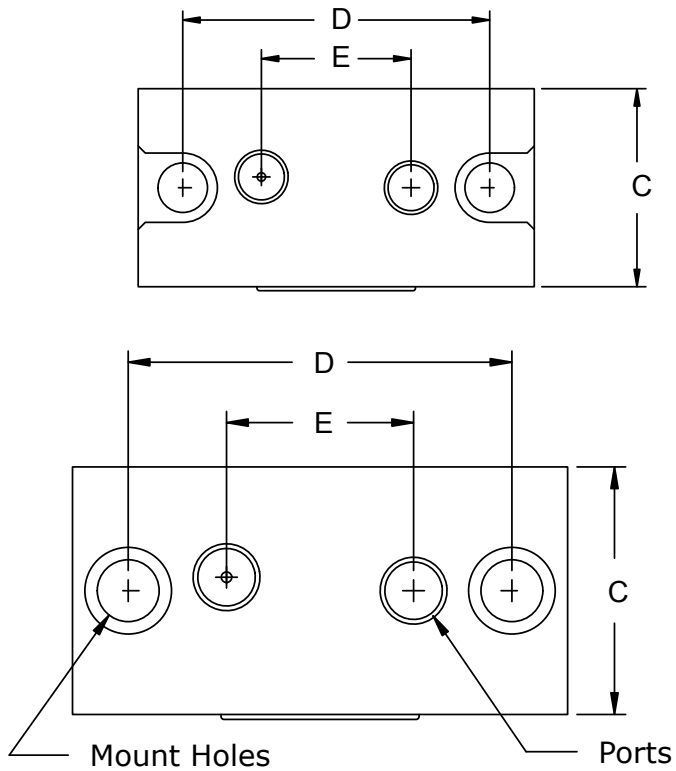

VIII. Parts Explosion for the SST-12, SST-16, and SST-25

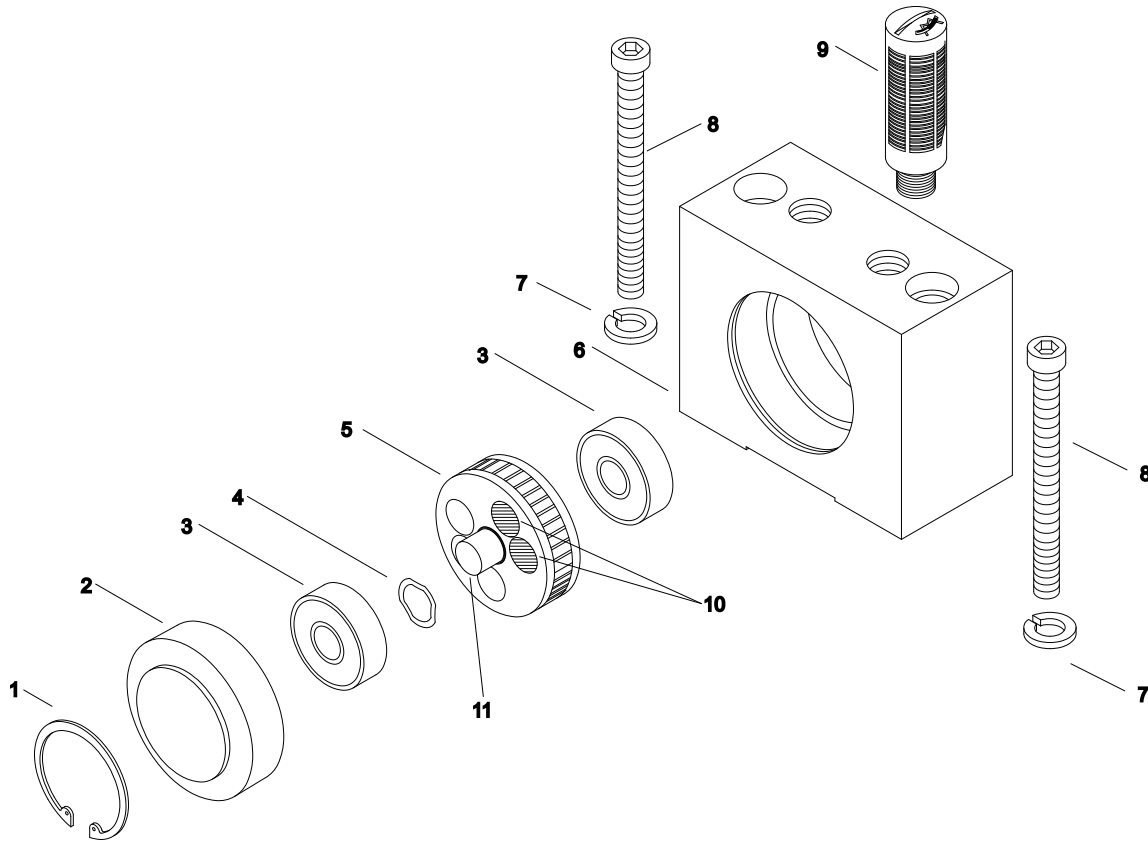

IX. Parts List for the SST-12, SST-16, and SST-25

NO.	DESCRIPTION	PART NUMBERS			
		SST-12 PN: 511012	SST-16 PN: 511016	SST-25 PN: 511025	QTY.
1	Retaining Ring Retaining Ring Size	348137	348175	348281	1
		5002-137	5002-175	5002-281	1
2	Side Cap	119912	119916	119925	1
3	Bearing*	381608*	382200*	382302*	2
4	Wave Washer	338505	338506	338510	1
5	Turbine Wheel	199912	199916	199925	1
6	Turbine Housing	149912	149916	149925	1
7	Lock Washer	338704	338706	338708	2
		1/4"	3/8"	1/2"	
8	Socket Cap Screw	336922	337130	337247	2
		1/4" x 2 1/4"	3/8" x 3"	1/2: x 4 3/4"	
9	Muffler	270302	270304	270306	1
		1/8"	1/4"	3/8"	
10	Weight - the Unbalance	199812	199816	199825	2
11	Shaft	209912	209916	209925	1

*The bearings in the Global Turbine SST vibrators are NOT standard bearings. They have special grease, with a precise fill, for the high-speed rpm's. Replacement bearings must be purchased from Global Manufacturing. Standard bearings will have a very short life and performance of the vibrator will be less than adequate.

X. Parts Explosion for the SST-35

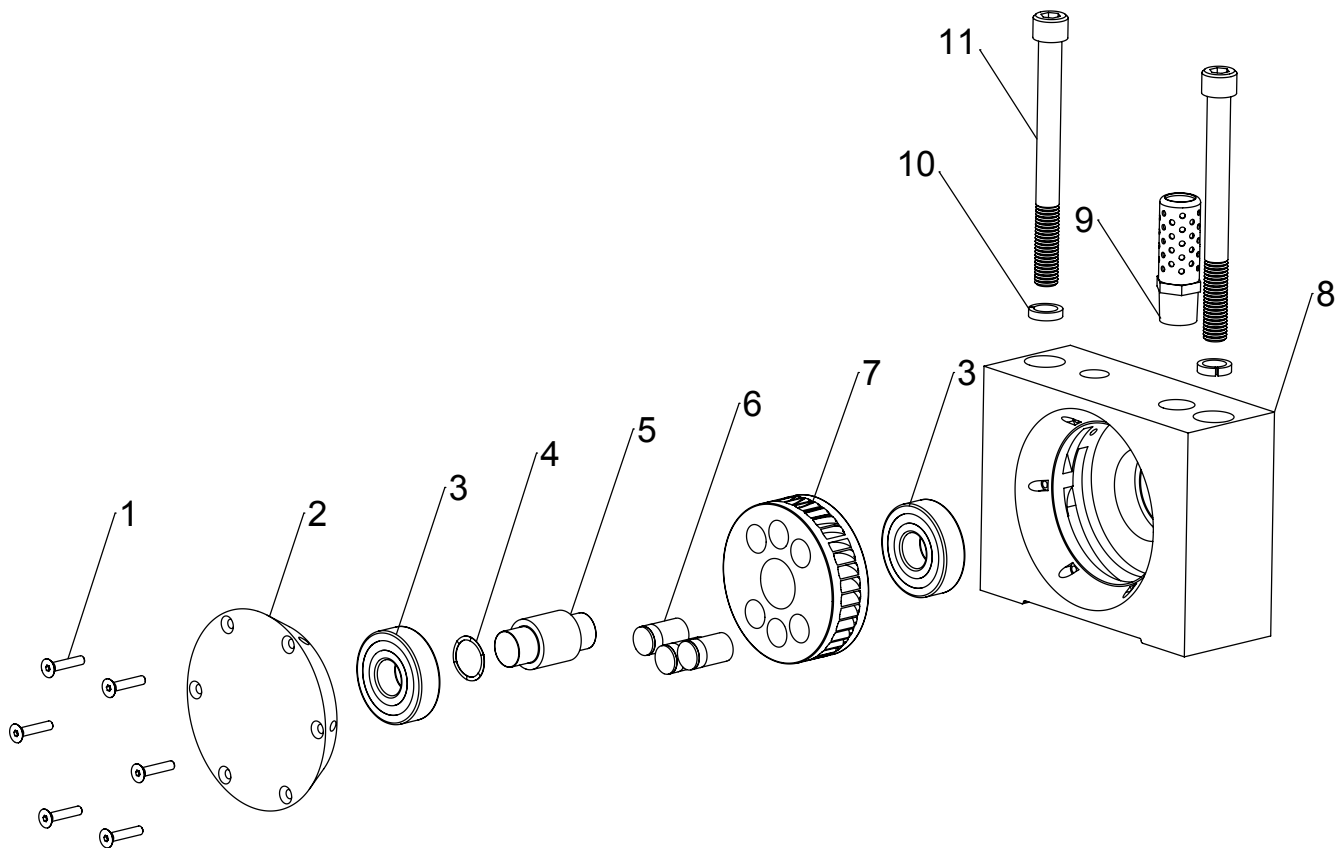

XI. Parts List for the SST-35

NO.	DESCRIPTION	PART NUMBERS	QTY.
1	Screw FSH#10 - 24 - 1"	3348066	6
2	Side Cap	119935	1
3	Bearing*	382304	2
4	Wave Washer .812" x .983" x .08" x .01"	338551	1
5	Shaft	209935	1
6	Weight - the Unbalance	199835	3
7	Turbine Wheel	199935	1
8	Turbine Housing	149935	1
9	Muffler - 3/8"	270008	1
10	Spring Washer 1/2" F/SCS	338708	2
11	Screw SCS 1/2" - 13 x 5 1/2"	337255	2

***The bearings in the Global Turbine SST vibrators are NOT standard bearings. They have special grease, with a precise fill, for the high-speed rpm's. Replacement bearings must be purchased from Global Manufacturing. Standard bearings will have a very short life and performance of the vibrator will be less than adequate.**

XII. Assembly & Disassembly SST-12, SST-16, SST-25

Global turbine vibrators are easily repaired if the proper procedures are followed. The only moving parts are the rotor and rotor bearings. The only wearing parts are the rotor bearings.

TOOLS REQUIRED

1. Internal type retaining ring pliers
2. One ton Arbor Press
3. Propane torch
4. Cleaning solvent, brushes, and shop cloths
5. Compressed air (clean)
6. Medium ballpeen hammer
7. 2 small pry bars
8. Global bearing kit
9. Denatured alcohol
10. Vise

PROCEDURE

1. Remove the muffler and air inlet line from the vibrator.
2. Remove the vibrator from the mounting surface.
3. Cover the inlet and outlet ports with tape. Clean the outside of the unit.
4. Wash hands prior to disassembly and again before assembling the vibrator.
5. Use the retaining ring pliers to remove the retaining ring. Note that the ring is beveled on the side facing you.
6. The turbine cap has a taper press fit to the cap bore. Insert the pry bars under the lip of the retaining ring. Pry evenly until the cap releases from the housing. Note the location of the cap bearing, which is pressed in the cap.

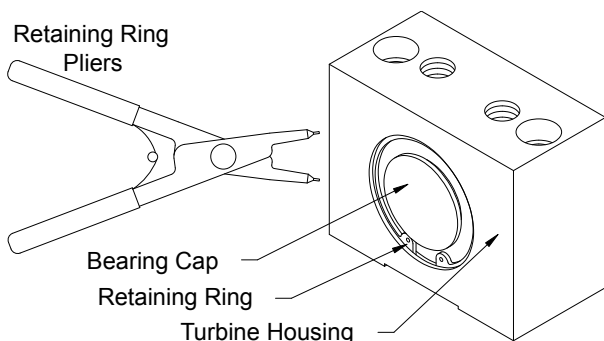

7. After the cap (with bearing) is removed, slide the wavy washer and rotor from the housing. Note the wavy washer on the cap side of the rotor. DO NOT assemble the unit without this washer. (See Parts List on page 8).

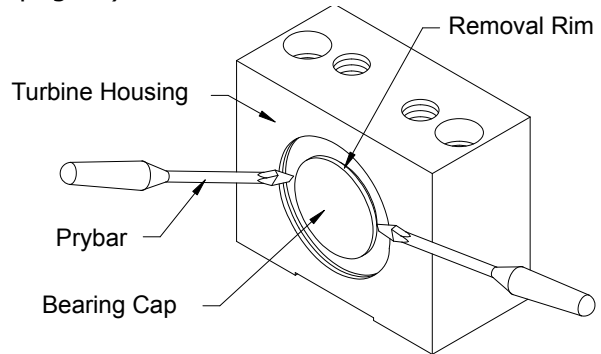

8. Place the housing in a vise. Use the ballpeen hammer to tap the tapered end of the bearing removal tool into the inner race of the housing bearing. The tool should be inserted tight enough to resist removal by hand.

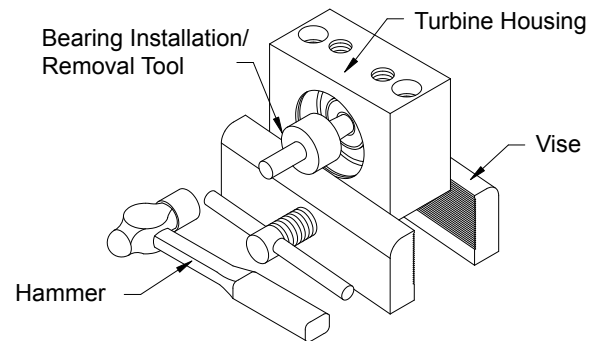

9. Use a torch to heat the outside of the turbine housing where the bearing is located. Constantly move the torch to ensure even heating. Continue heating until the housing expands enough so that hand pressure applied to the bearing removal tool will release the bearing. Remove the bearing and allow the housing to cool before handling.

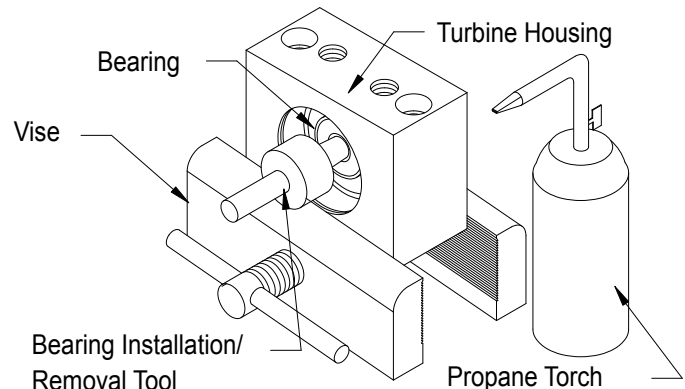

10. Place the bearing cap in the vise. Repeat step 9 to remove bearing from cap. Do not clamp the bearing cap by any surface except the removal rim. (Damage to the press fit contact surfaces will impair assembly and operation of the completed unit). Note: If an Arbor press is not available insert the new bearings before the housing and cap cool.
11. Clean the housing, bearing cap, and rotor assembly with denatured alcohol. The rim of the cap is coated with a dry lubricant to prevent seizure in the housing. DO NOT clean the cap rim with solvent. Wipe the cap rim clean with a shop cloth. **Note: The bearings in Global turbine vibrators are not standard bearings. They have special grease, with a precise fill, for the high-speed rpm's. Replacement bearings must be purchased from Global Mfg.**
12. To install the new bearings in a cool housing or cap, the bearing installation tool (opposite end of removal tool) and an Arbor press must be used. Lightly lubricate the outer rim of the new bearings. Place the housing in the Arbor press. Press the housing bearing into the housing until the bearing seats lightly in the bottom of the bore. Repeat the procedure for the cap bearing.

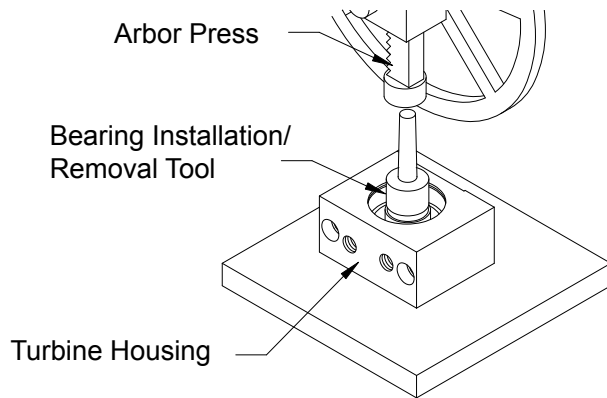

13. Replace the rotor in the housing. Make sure the turbine slots face the inlet jet.

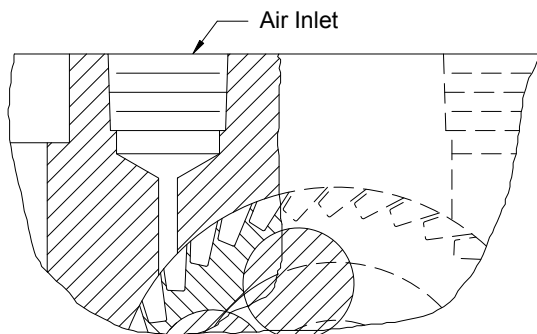

14. Replace the wavy washer on the rotor shaft.
15. Lightly coat the outer rim of the cap with light oil. Carefully replace the cap in the rotor shaft. Slide the cap into the housing until almost seated against the shoulder in the housing.
16. Use the Arbor press to seat the cap against the shoulder in the bore. Rotate the assembly 90° in the press and seat the cap again. This will assure even seating of the cap against the shoulder stop.

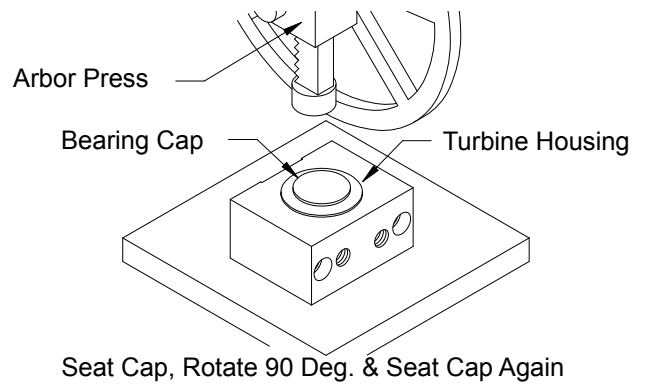

17. Replace the retaining ring in the housing groove. Make sure the beveled side faces you.

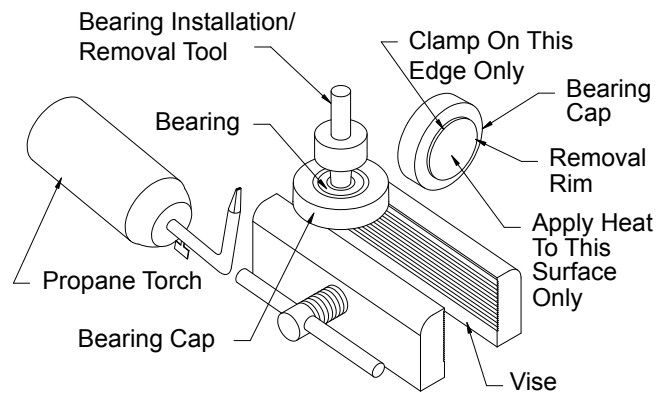

18. Reinstall the muffler and inlet hose fitting after mounting the vibrator back onto its mount.

XIII. Assembly & Disassembly SST-35

TOOLS REQUIRED

1. 1/8" Hex Key
2. One ton Arbor Press
3. Propane torch or other heat source such as an oven
4. Cleaning solvent, brushes, and shop cloths
5. Compressed air (clean)
6. Medium ballpeen hammer
7. Global bearing kit

PROCEDURES

1. Remove the muffler and air inlet line from the vibrator.
2. Remove the vibrator from the mounting surface.
3. Plug or cover the inlet and outlet ports with tape. Clean the outside of the unit.
4. Wash hands prior to disassembly and again before assembling the vibrator.
5. Use a 1/8" key to remove the 6 each 10-24 flat head screws which secure the housing cover. The cover should be loose enough to tap free of the housing.

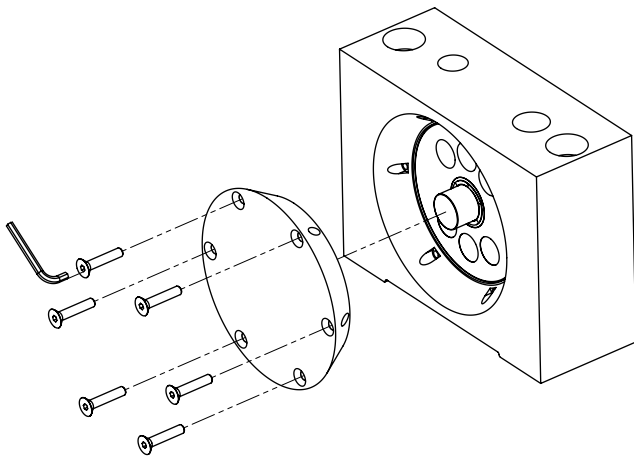

6. Remove the rotor from the housing. Note the wave washer on the cover side of the rotor. Also note the spacer rim cut into the other side of the wheel. The side of the rotor with the wave washer must face the cover upon reassembly.

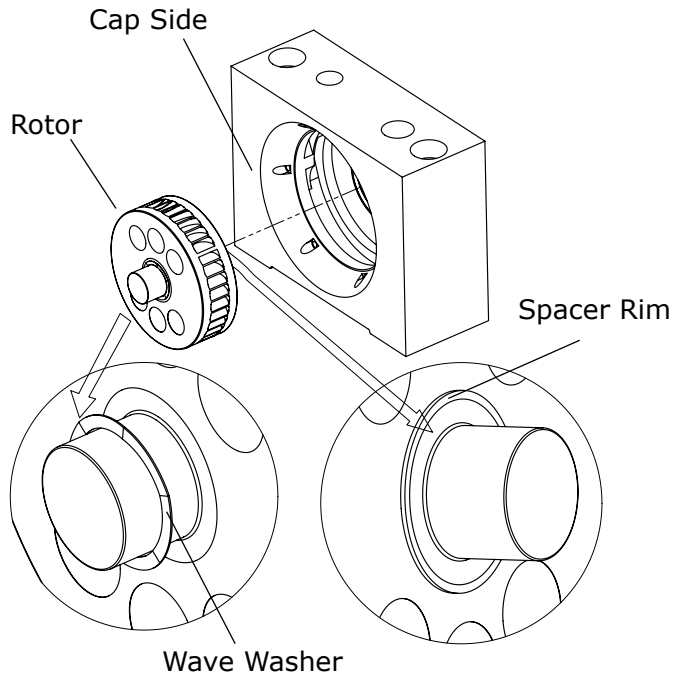

7. During this next procedure work on a heat resistant surface. Place the housing open side down. Place the cover on something like wooden blocks (must be heat resistant) to elevate it about 1" from the surface. Make sure the bearing bore is clear, so that the bearing can drop out when heated.

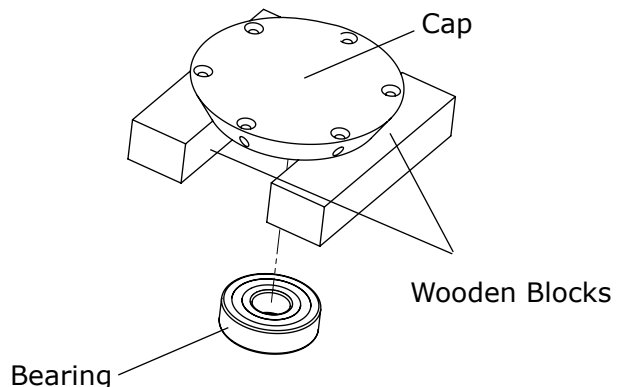

- Heat the housing and cover evenly to approximately 300° F until the bearings drop out via the expanding aluminum. This may be facilitated by tapping the housing and the cover on your work surface. Remember to use heat resistant gloves or something to protect your hands from the 300° F heat.

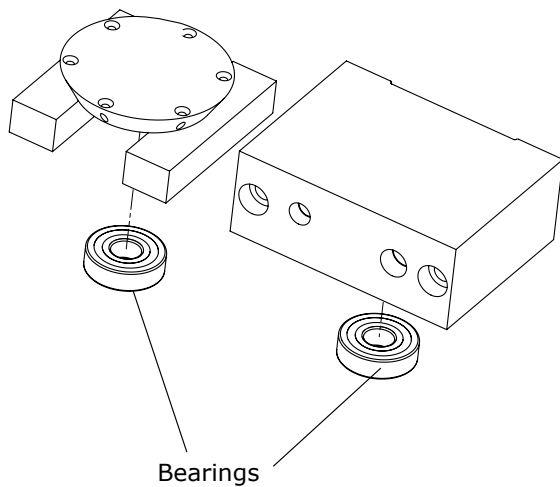
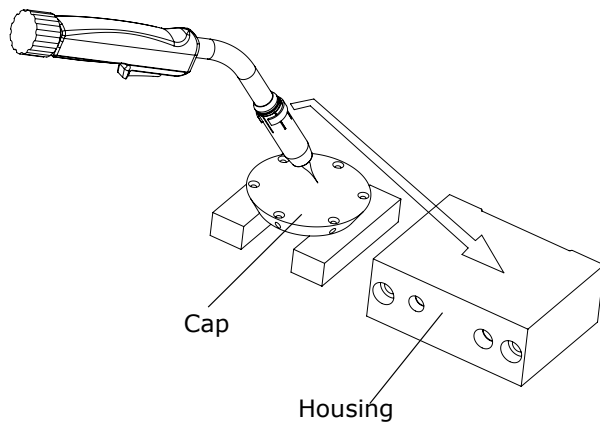

- Clean the housing, cap, and rotor assembly with cleaning solvent and clean shop towels.

- To install new bearings into the housing and cap, lightly lubricate the outer race of the new bearings with light oil (30W for example) and press them into their bores with the Arbor press. Use a tool that puts pressure on the **outer race only**. Press bearings into the bottom of their bores.

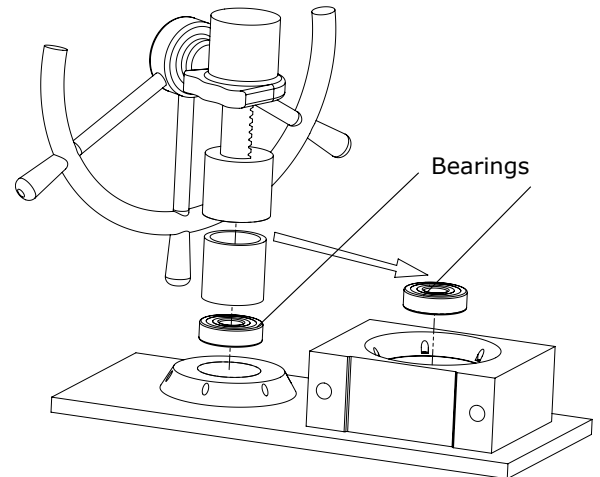

- Check the rotor shaft for wear on weight side. If there is any visible wear, the shaft must be replaced.
- Replace the rotor into the vibrator housing (spacer rim away from cap side). The slots should face inlet jet.

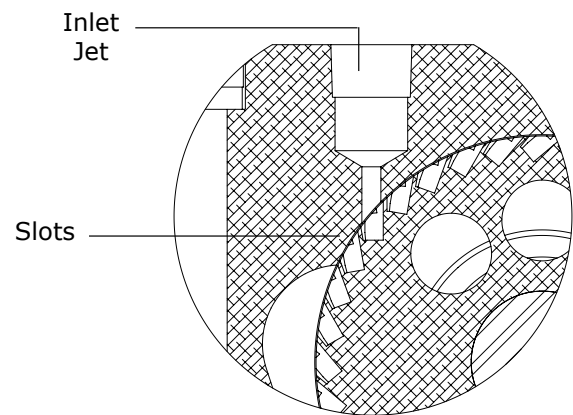

- Replace wave washer on shaft.
- Replace cap on rotor shaft and into housing.
- Replace cap screws, tightening securely in a crisscross pattern.



AIRMATIC INC founded in 1944, is a woman-owned Industrial Distributor, with installation and maintenance capabilities, offering equipment, machinery, and shop supplies to the Industrial, Construction, Utility, Government, and Commercial Markets. Our products and services are sold through three business units:

The **MATERIALS MANAGEMENT GROUP** provides products and services to industries that convey, store, transport, and process powders and bulk solids from aggregates, cement, and chemicals to foods, grains, metals, power generation, and waste water treatment applications;

The **SERVICE GROUP** provides fabrication, installation, and maintenance services to improve bulk materials handling efficiency; mechanical clean-out services for silos and hoppers to eliminate material flow problems; and shop repair/rebuilding and modifications services of products sold by the Company.

The **TOOL GROUP** provides power tools, personal protective equipment, materials-handling equipment, shop equipment and MRO supplies used for production, fabrication, assembly, metal removal, maintenance, and storage in manufacturing, construction, utility, and commercial applications. Our Customers tell us that by choosing **AIRMATIC** to solve their problems, they gain increased productivity, decreased costs, and a safer, cleaner work environment.

AIRMATIC INC

284 Three Tun Rd. Malvern, PA 19355

215.333.5600

infocenter@airmatic.com

airmatic.com