

Design Series

Operating Instructions

Global® External
Pneumatic Vibrators

MODELS:

C3-1.5-4AC

C3-2.0-4AC

C3-2.5-4AC

C3-3.0-4AC

C3-6.0-4AC

C3-6A-4AC

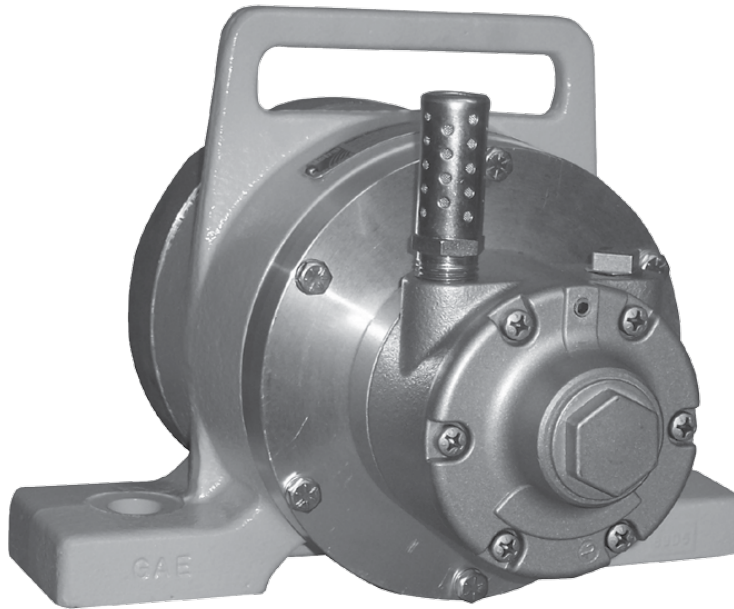

C3_PNEU_03/16/09 rev 1

Table of Contents		Page
I.	Introduction	2
II.	Installation Procedures	3 - 4
	Channel Irons - Sizes & Mounting	3
	Placement on Channel Iron	4
	Direction of Rotation	4
III.	Mounting Locations on Hopper	5
IV.	Bidirectional Air Motor	6
	Filter, Regulator, & Lubrication	6
V.	Operation	7
VI.	Air Motor Maintenance	7
VII.	Adjusting the Eccentric Weights	8
VIII.	Vibrator & Bracket Dimensions	9
IX.	Vibrator Parts Explosion	10
X.	Vibrator Parts List	11
XI.	Air Motor Parts Explosion & Parts List	12
XII.	Assembly & Disassembly	13 - 17
XIII.	Vibrator & Motor Performance Data	17
XIV.	Troubleshooting	18

I. Introduction

For optimum performance, cycle the vibrator on and off. The vibrator acts as a friction reducer and once the bulk solid is set into motion, gravity should do the rest. Do not operate the vibrator on an empty hopper as this may cause structural damage to the hopper.

Vibrators should be operated only when discharge gates are open. Operating the vibrator with the discharge gate closed will cause the material inside the structure to compact.

Vibration has two important elements – Frequency and Amplitude. Frequency is the speed (RPM) or the number of vibrations per minute. It is controlled by the air flow to the pneumatic vibrator. Amplitude is the unbalance or the amount of eccentric weight. The faster the eccentric weights turn the more force output generated. Force and frequency work together. It is not necessary to use a lot of force when you have the frequency.

Safety Precautions

- Follow all mounting instructions.
- Always use a safety cable or chain for support.
- Do not operate vibrators when structure is empty.
- Do not operate vibrators when gate is closed or conveyor is stopped unless compaction of material is desired.
- Wear ear protection for 90+ decibel levels.
- Do not operate vibrators without side covers.
- Do not operate above the maximum pressure of 100 P.S.I. (7 bar).
- Use only compressed air to drive the motor.
- Do not use combustible gas to drive the air motor.
- Do not run the air motor (if disassembled from vibrator) at high speeds with no load. It will cause excessive heat and damage the motor.
- Always disconnect airline before maintenance.

II. Installation Procedures

Caution

Do not mount the vibrator directly to the structure wall. Use a channel iron stiffener for proper mount rigidity and as the transducer of the vibrational energy.

The key to successful vibration is the correct mounting procedure. Rotary vibration resonates the material inside the structure when the vibrator is mounted correctly. The vibrator should appear motionless. There should not be a large amount of motion or noise.

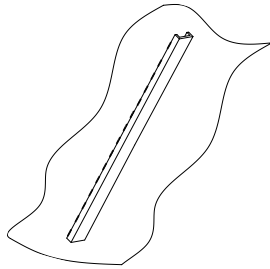

Attach the vibrator to the channel iron. Stitch weld bolts to the back of the channel iron or the channel iron may be drilled and tapped to accept the mounting bolts. An alternate method is to cut a second channel iron slightly longer than the footprint of the vibrator. Stitch weld the second channel iron to the first. Do not weld the ends. Mount the vibrator to the second channel iron.

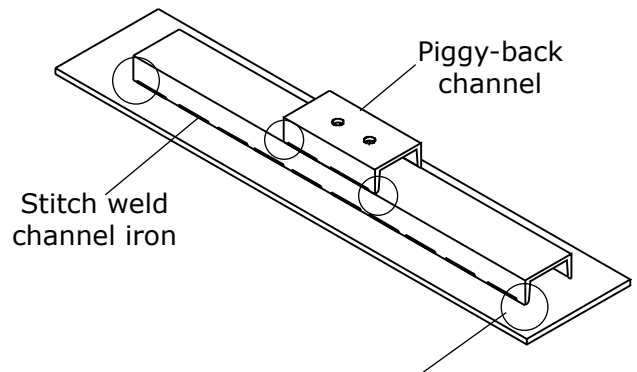

Channel Irons - Size & Mounting

Important!

The channel iron should be at least two-thirds of the height of the sloped portion of the hopper but no greater than 10 feet (3 m).

The channel iron should be at least two-thirds the height of the sloped portion of the hopper, but not less than 6 feet (1.83 m) in length. The channel iron width should not be less than the base width of the vibrator. See chart below for recommended channel sizes. DO NOT install more than one vibrator on the same channel iron or use a channel iron shorter than the recommended length. A short channel may flex the bin wall.

Channel Iron Size:

C3 Models having up to a 3 lb-in unbalance use:

C5 x 6.7 LB/FT (C130 x 10 kgs/m) channel iron.

C3 Models having 4 to 6 lb-in unbalance use:

C6 x 13 LB/FT (C150 x 19 kgs/m) channel iron.

The "unbalance" (also called "weight" or "eccentric weight") is the middle number in the model number. For example, the unbalance of a C3-3.0-4AC is "3 lb-in". If the middle number is "6A" it has a set of weights that will adjust from 1.5 lb-in up to 6 lb-in. Use the appropriate size of channel based on your weight setting.

Do not weld the ends of the channel iron - this allows the vibrational force to "escape". Solid welded ends trap the force which can cause stress cracks.

Stitch weld the channel iron vertically to the slope portion of the bin wall. Weld 3 inches (7.5 cm), skip 1 inch (2.5 cm), weld 3 inches (7.5 cm), etc... Leave 1 inch (2.5 cm) un-welded on the ends and corners. This allows the vibration to dissipate out the ends of channel without causing stress cracks to the hopper or bin. By doing so, should the weld fail, the entire mount will not fall off. Do not mount the channel iron horizontally.

Secure the vibrator to the channel iron with SAE coarse thread grade 8 plated bolts with lock washers or an adhesive such as Loctite® 262. Tighten bolts in a sequential process. At least two passes are required in most situations. Give all bolts the same torque value. Grade 8 bolts can handle more torque than standard bolts. If Loctite® is not used, retorque the bolt after the vibrator has operated for a few minutes and check tightness often. If Loctite® is used do not retorque the bolts as this will break the Loctite® bond.

Attach a safety cable to a stronghold (not the channel iron mount), which is higher than the mounted vibrator and capable of holding the vibrator's weight.

Placement on Channel Iron

The axis of rotation of the eccentric weights for all rotary vibrators should be oriented in the direction of material flow. The shaft of the vibrator should ideally be in a horizontal position to prolong bearing life.

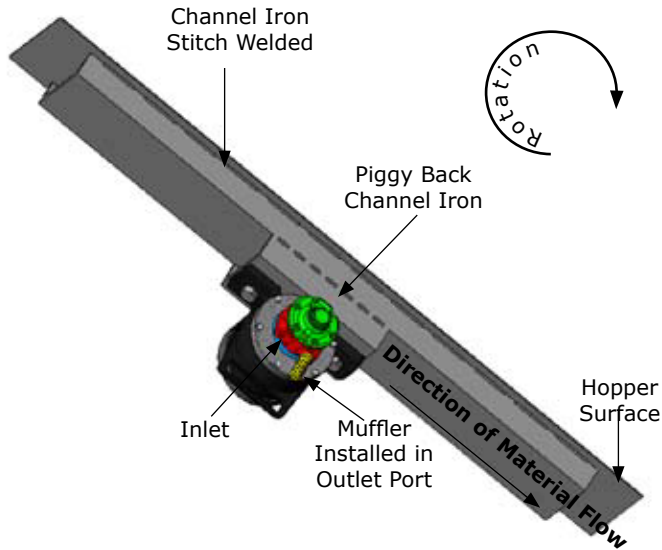

Installation on Chutes and Flow Pipes

Mount channel iron stiffeners vertically or in the direction of material flow. Center the channel if the chute is less than 6 feet (1.83 m) in width. If the chute is greater than 6 feet in width, use two vibrators on separate channel irons. To maximize each vibrator's radius of influence; center each channel iron in each half of the chute. Each channel iron should be located $\frac{1}{4}$ of the chute width from the edge and $\frac{1}{2}$ of the chute width apart. (E.g. – for a chute 8' wide, the channel iron locations would be 2' from each edge and 4' apart.) When wall thickness is less than $\frac{1}{8}$ ", additional reinforcement may be required.

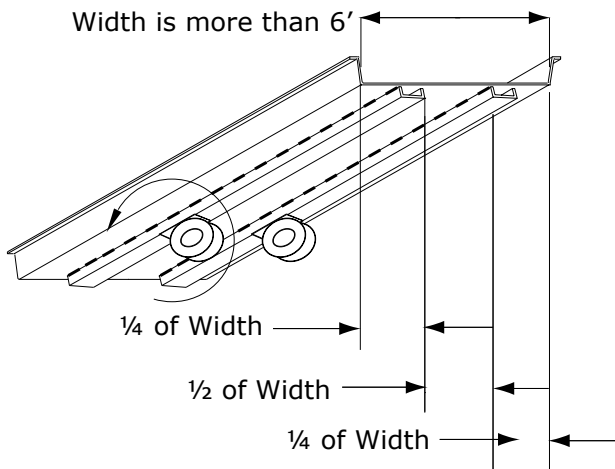

Installation on Rail Cars

Install the C3 model vibrator onto a C3/GBM wedge bracket and slip it into the pocket on the railcar. Eccentric weights should rotate clockwise to wedge bracket into railcar hopper pocket.

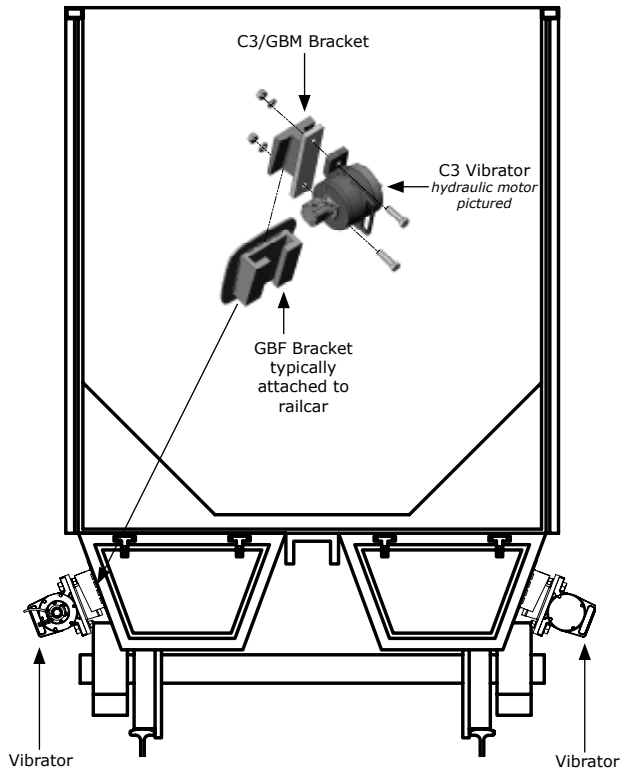

Direction of Rotation

C3/CC Clamp-On Bracket: The eccentric weights of the vibrator should rotate in the same direction as the tightening of the clamp bolts if the C3 vibrator is mounted to a C3/CC clamp-on bracket. This will prevent the clamp bolts from loosening. The clamp bolts turn (tighten) in a clockwise direction. Look at the vibrator from the motor side. The inlet port is on the right side of the motor for clockwise rotation.

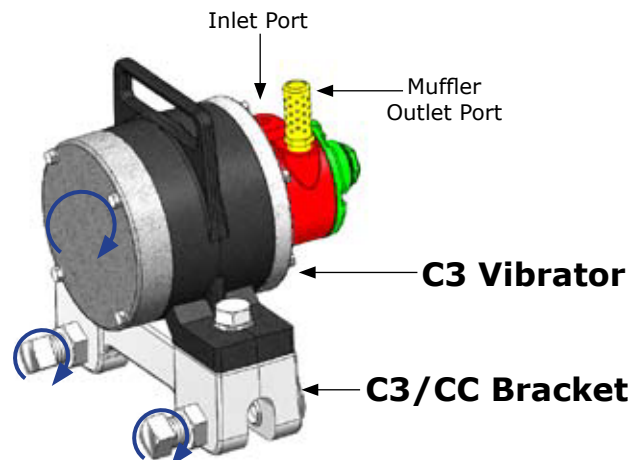

III. Mounting Locations on Hoppers

Single Vibrator

Install a channel iron stiffener on the outside of the sloping wall $1/3$ the distance above the discharge opening.

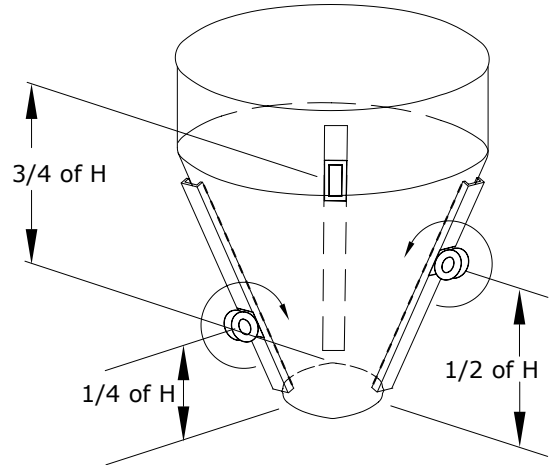
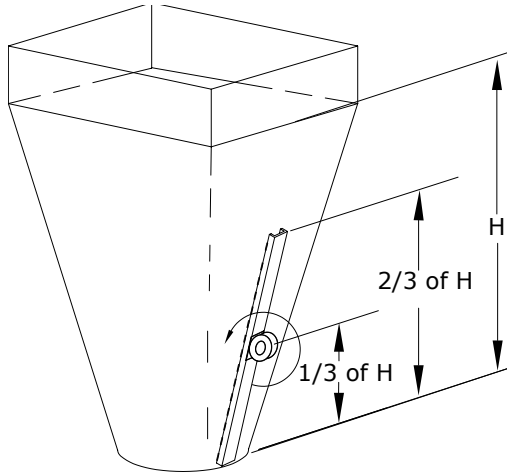

Three Vibrators

Install channel iron stiffeners mounted 120° apart. Install the first vibrator on the outside of the sloping wall $1/4$ the distance above the discharge opening. Install the second vibrator on a separate channel iron at $1/2$ the distance above the discharge opening. Install the third vibrator on the remaining channel iron at $3/4$ the distance above the discharge opening.

Multiple Vibrators

Use more than one vibrator when the diameter or width of any wall is greater than 12 feet (3.66 m). Always mount the vibrators on different planes.

Two Vibrators on Round or Square Hoppers

Install channel iron stiffeners 180° apart. Install one vibrator on the outside of the sloping wall $1/3$ the distance above the discharge opening. Install the second vibrator on the outside of the opposite sloping wall $2/3$ the distance above the discharge opening.

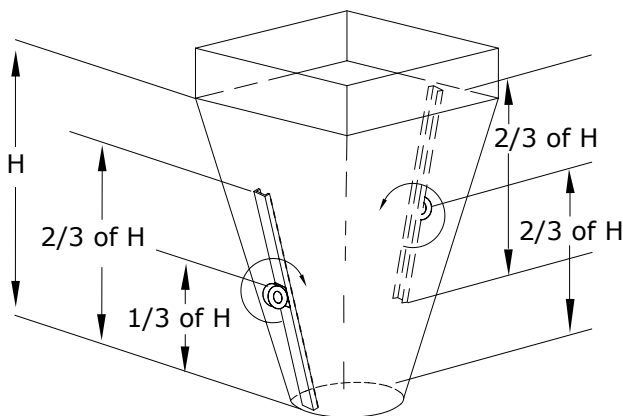
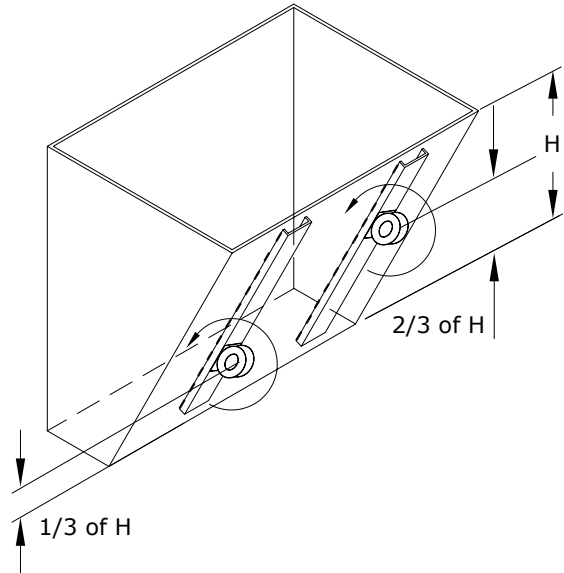

Two Vibrators on Rectangular Hoppers

Install channel iron stiffeners on opposite sides of the long walls. Install one vibrator on the outside of the sloping wall $1/3$ the distance from the discharge opening. Install the second vibrator on the outside of the opposite sloping wall $2/3$ the distance above the discharge opening. When only one wall slopes, mount both stiffeners on it. Equally space the stiffeners on the wall. Place one vibrator $1/3$ above the discharge opening on one channel iron and the other vibrator $2/3$ above the bin's discharge opening on the second channel.

IV. Bidirectional Air Motor

The motors of the Design Series vibrators are bidirectional; therefore the eccentric weight rotation can be reversed by changing the hose connections. (Change the inlet to the outlet and the outlet to the inlet.)

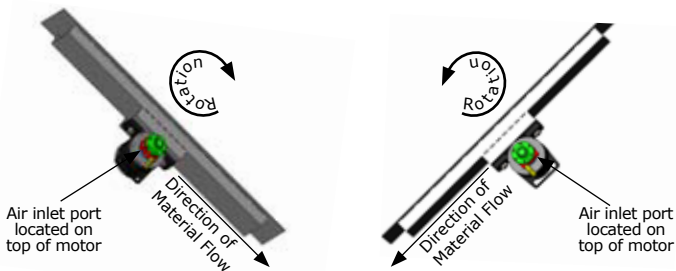
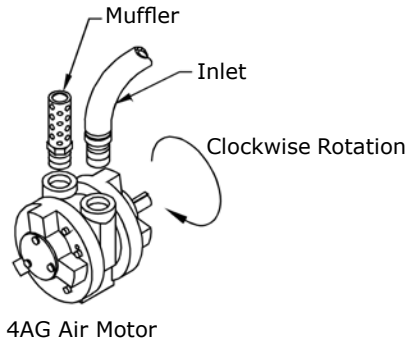

Hint: Airline inlet connection is on the “top” (towards the sky) of the motor for the correct eccentric weight rotation. The exhaust port will be on the “bottom” (towards the earth).

Hose Sizes & Recommendations

Inlet

Clean the compressed air connection with low pressure air to remove any dirt from the line before connecting the ports.

Use an air hose that is the same size or larger in diameter as the inlet port (1/2”) of the vibrator. Use larger air lines if the main feed line is 25 feet (7 meters) or more away. Connect air line to the highest port, as shown in drawing above, or on the side, in the direction of material flow. Use a short, flexible hose between the vibrator and the main air line if the main line is metal to avoid strain on the vibrator motor ports. Allow a loose bend of 9” to 16” (23 cm to 41 cm) to be formed by the hose to prevent cracking from vibration.

Outlet

Screw muffler into the exhaust port to keep contaminants out of the vibrator, especially when the vibrator is turned off. Exhaust air may be exhausted away, via a hose, to reduce noise and contamination. To do this use an exhaust hose that is at least one size larger than the inlet hose.

Filter, Regulator, & Lubrication

Filter

Install a 5-micron filter in the airline before the connection to the motor. Drain airline filter regularly and examine the element for signs of clogging. Remove debris if necessary.

Regulator

Next install a pressure regulator or a needle valve to control the air flow, which controls the speed. A regulator provides constant speed control even as the plant air pressure varies. Alternatively, a needle valve will control the speed as long as the plant air pressure does not change. Do not connect the vibrator directly to the plant air. This could cause the motor to operate faster than its maximum pressure rating. Maximum pressure is 100 p.s.i.

Use a ball valve or solenoid valve to turn the vibrator on and off.

Automatic Lubrication

Install an automatic airline lubricator in the airline as close as possible, but no further than 18 inches (1/2 meter) from the vibrator motor. Position lubricator level with or above the air motor, so that the oil mist will blow directly into or fall down into the motor. Fill oil reservoir to the proper level with SAE 10W high detergent or non-detergent motor oil. Adjust lubricator to feed 1 drop of oil for every 50 CFM of air when unit is running, or 1 drop of oil per continuous minute for run time. Do NOT overfeed oil or exhaust air may become contaminated. Check oil level daily and refill reservoir as necessary.

The vibrator may be run continuously at speeds up to the related running conditions shown in the performance data on page 17.

Why Lubricate?

Lubricating is necessary to prevent wear and rust on all moving parts. Excessive moisture in airline may cause ice to form in the muffler when air expands as it passes through the motor. Install a moisture separator in the airline and an after cooler between the compressor and air receiver to help prevent moisture problems.

V. Operation

Warning

Do not use combustible gases to drive this motor.

Wear hearing protection. Sound level may exceed 85 dBA.

The air supply must be clean and relatively dry.

For optimum performance, cycle the vibrator on and off. The vibration acts as a friction reducer and once the bulk solid is set into motion, gravity will do the rest. Do not operate vibrator on an empty hopper as this may cause structural damage to the hopper.

Operate vibrators when discharge gates are open. If gates are closed the material will compact when vibration is applied.

The vibrator should appear motionless. Damage may occur to the vibrator and/or structure on which it is mounted, if the mount is loose or flimsy.

Direction of the eccentric weight rotation is normally in the same direction as the desired direction of material flow. See previous page for instructions.

“Tune” your vibrator to get maximum performance. Vary the frequency of the vibration by adjusting the CFM of the pneumatic motor. Bulk materials resonate at their natural frequency. Approximate that frequency by adjusting the RPM (speed) until the material flows freely. It is NOT necessary to run your vibrator at full throttle to get results. You may only need a fraction of the available air.

Vane Life

Vane Life depends on the operating pressure, quality of the compressed air, speed, lubrication, and motor maintenance. In normal operating conditions inspect vanes after 5,000 to 8,000 hours of operation.

VI. Air Motor Maintenance

Caution

Disconnect air supply and vent all airlines before maintenance.

Wear eye protection when flushing the motor.

Do not use kerosene or other combustible solvents to flush motor.

Flushing

Flushing the motor to remove excessive dirt, foreign particles, or moisture & oil that occurs in the operating environment will help to maintain proper vane performance. Flush the motor if it is operating slowly or inefficiently.

Use Gast solvent (#AH255B) to flush motor. Do NOT use kerosene or any combustible solvents.

1. Disconnect airline & muffler.
2. Add flushing solvent directly to motor. If using liquid solvent pour several tablespoons directly into the intake port. If using Gast #AH255B spray solvent for 5-10 seconds into intake port.
3. Rotate shaft by hand in both directions for a couple minutes.

Wear eye protection for the next steps.

4. Cover exhaust port with a cloth and reconnect the airline.
5. Restart the motor at a low pressure of approximately 10 PSI (.7 bar) and run until there is no trace of solvent in the exhaust air.
6. Listen for changes in the sound of the motor. If the motor sounds smooth you are finished.

VII. Adjusting the Eccentric Weights of the C3-6A-4AC

The models with "6A" in the description have adjustable weights. To change the amount of vibration, reposition the weights (also referred to as the "unbalance" or the "eccentric weights") on the shaft, by removing and reinstalling an adjustment bolt.

1. Remove both covers.
2. Remove the adjustment bolt to allow inside weight to rotate on shaft. There are two weights on each side of the vibrator - an inside and outside. The inside weight (adjustable weight) is attached to the outside weight with the "adjustment bolt". The outside weight is fixed to the shaft with a set screw and a key (Do not loosen the set screw on the outside weight.).
3. Rotate the inside weight until the tapped hole lines up under the desired bolt hole of the outside weight and reinstall the adjustment bolt.
4. Repeat process to the weights on the opposite side of the vibrator.
5. **It is very important that the weights on both sides are set the same.**
6. Replace covers using 9 ft-lbs of torque. Make sure the motor coupling aligns with the pins on the weight.

Weight Position Guide

Notice the position of the adjustment bolt (black in color) at each weight setting.

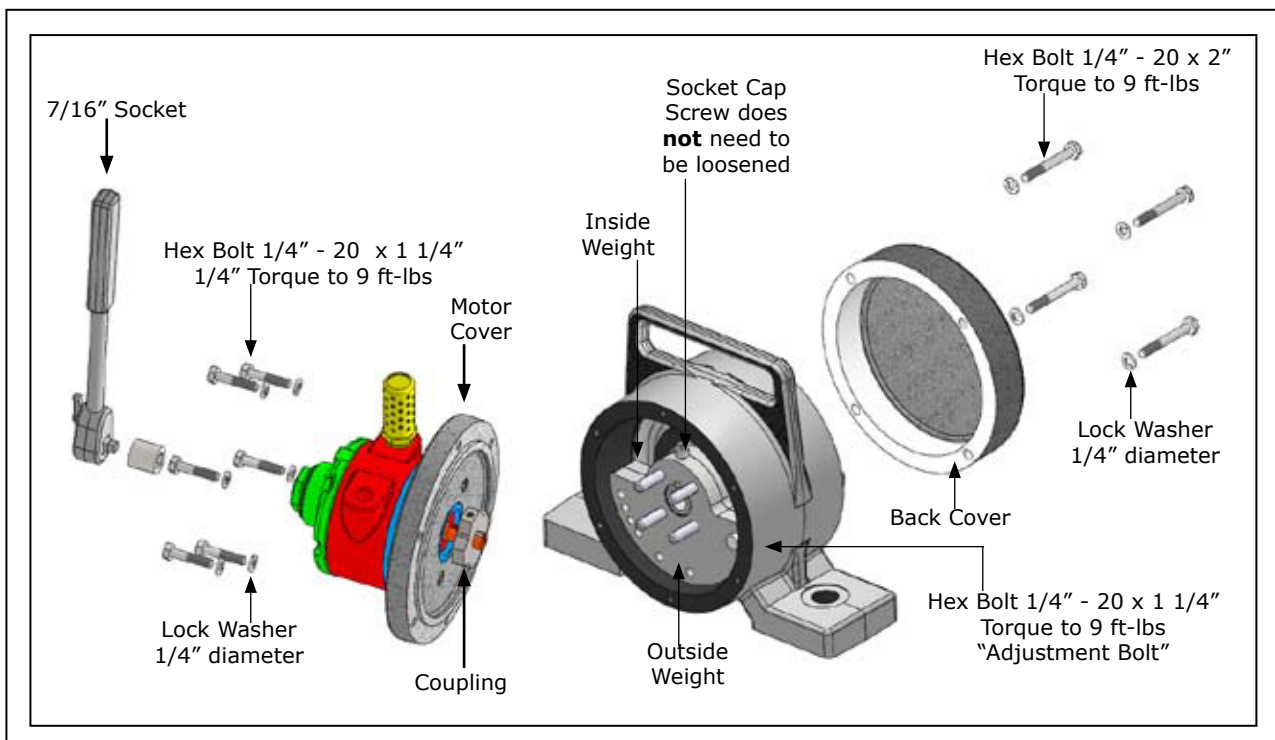
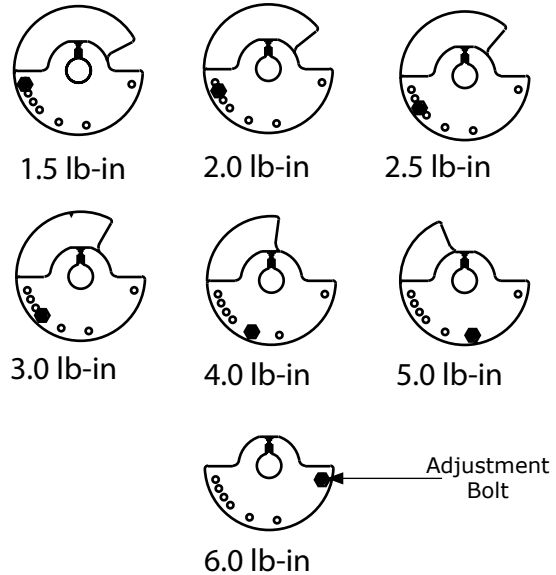

VIII. Vibrator Dimensions

All dimensions are in inches (millimeters).

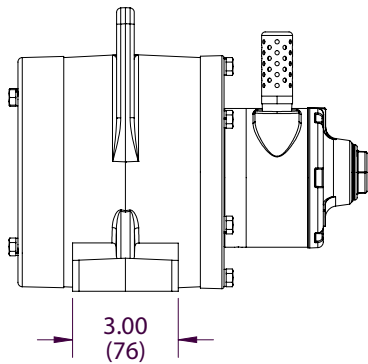
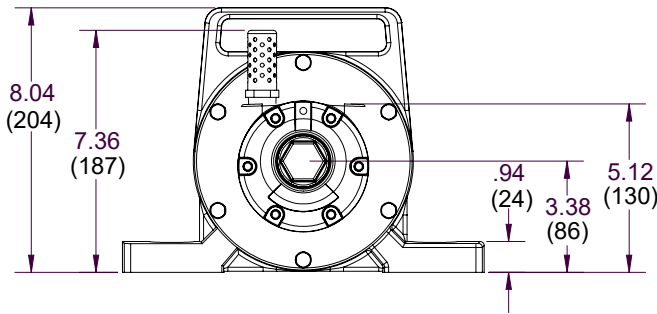
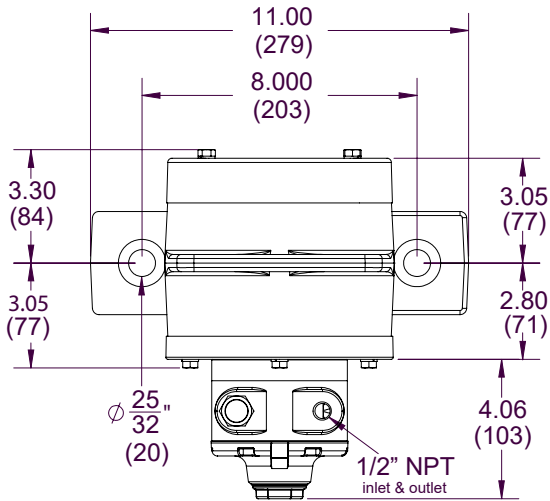

Brackets & Dimensions

All dimensions are in inches (millimeters).

C3/CC Bracket pn 167503

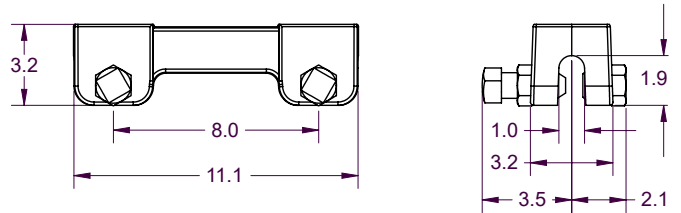
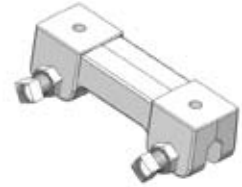

C3/GBM Bracket pn 167000

C3 vibrator is attached to the C3/GBM Bracket and inserted into the GBM Bracket.

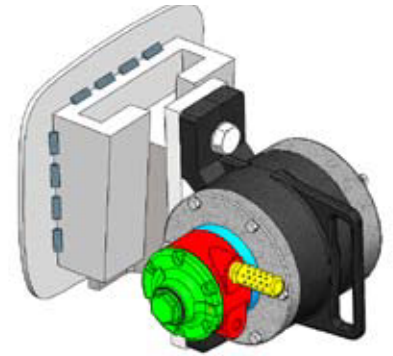

C3/GBM Bracket pn 167000

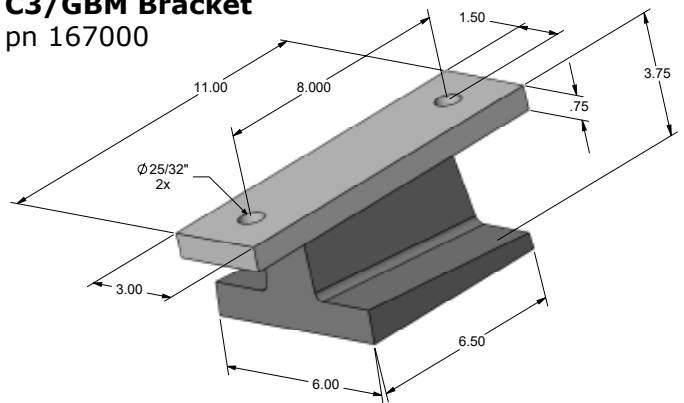

GBF Bracket

pn 167071

This bracket is typically found on railcar hopper pockets.



IX. Parts Explosion

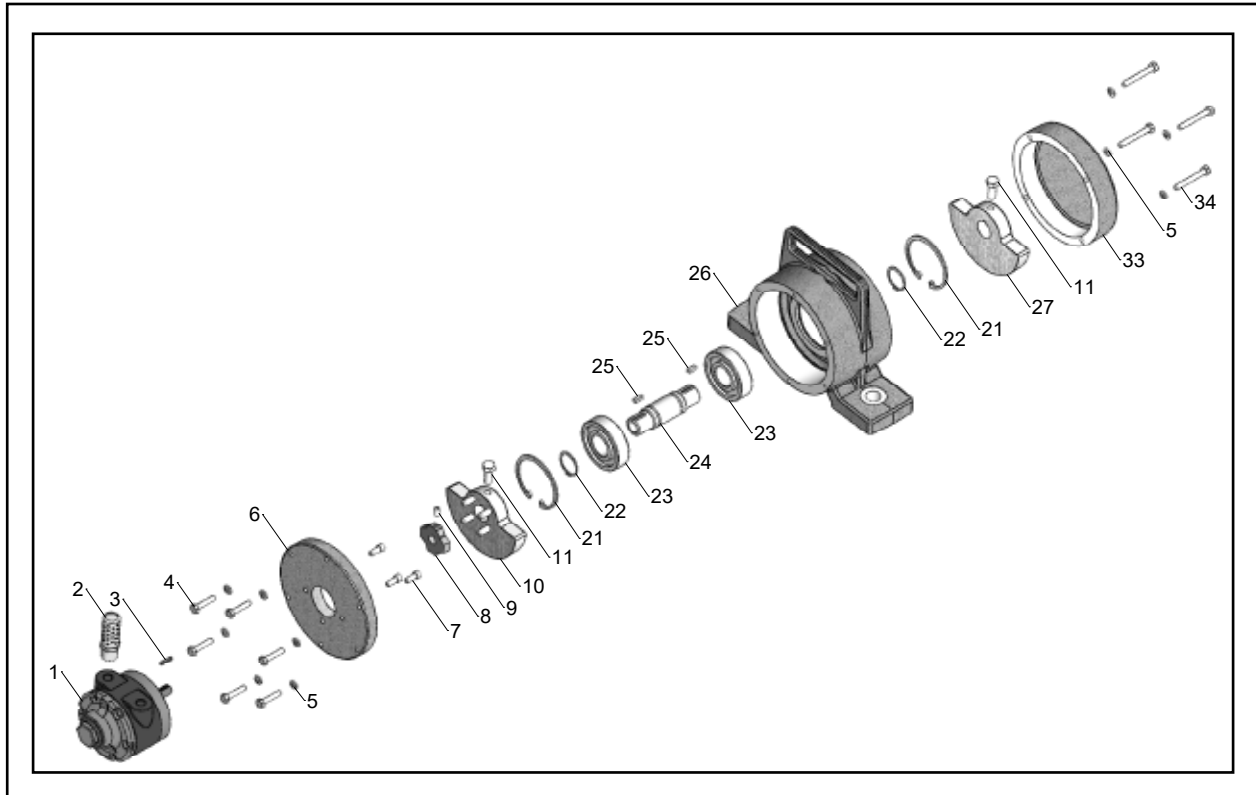

Weight Sets (the "Unbalance")

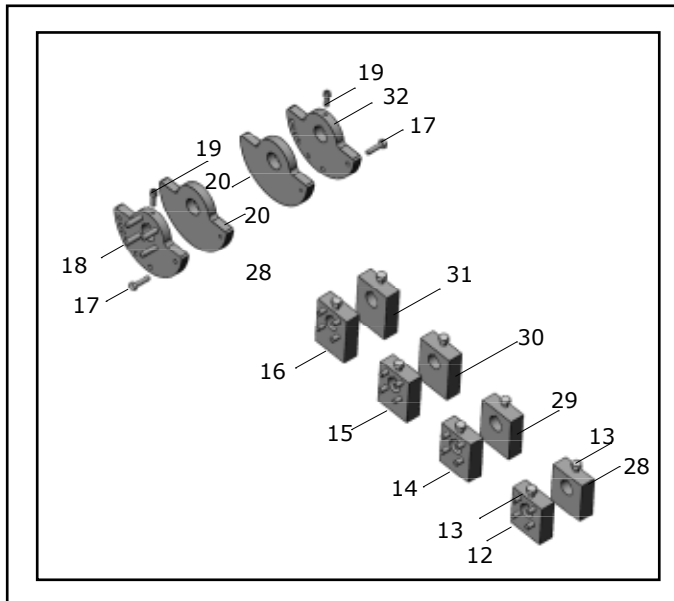

Model Number	Part Number
C3-1.5-4AC	534015
C3-2.0-4AC	534020
C3-2.5-4AC	534025
C3-3.0-4AC	534030
C3-6.0-4AC	534060
C3-6A-4AC	534066

Match the parts listed on page 11 with your model number. There are six different weight sets. A "C3-6A-4AC" means the vibrator is a "C3" model, the "6A" is a 6 lb-in adjustable weight, and the motor is a 4AG pneumatic motor. The model above is a C3-6-4AC (the weight is not adjustable). If your model is a C3-1.5-4AC the weights (item numbers 10 & 27 in the illustration above) are replaced with items numbers 12 & 28 illustrated on the left.

X. Vibrator Parts List

Item no.	Part number	Description	C3-1.5-4AC	C3-2.0-4AC	C3-2.5-4AC	C3-3.0-4AC	C3-6.0-4AC	C3-6A-4AC	
			Part # 534015	Part # 534020	Part # 534025	Part # 534030	Part # 534060	Part # 534066	
			Quantity						
1	240440	Air motor 4AG	1	1	1	1	1	1	
2	270008	Muffler	1	1	1	1	1	1	
3	Included with motor	Key 1/8" sq. X 3/4"	1	1	1	1	1	1	
4	330012	Hex bolt 1/4"-20 x 1-1/4"	6	6	6	6	6	6	
5	338104	Lock washer 1/4"	10	10	10	10	10	10	
6	110930	Motor cover	1	1	1	1	1	1	
7	336906	Screw SCS 1/4-20 x 5/8"	3	3	3	3	3	3	
8	203045	Coupling	1	1	1	1	1	1	
9	336105	SSS 1/4"-20 x 1/2"	1	1	1	1	1	1	
10	194206	Drive weight 6.0 lb"	-	-	-	-	1	-	
11	330210	Hex bolt 3/8"-16 x 1"	-	-	-	-	2	-	
12	193215	Drive weight 1.5 lb"	1	-	-	-	-	-	
13	330207	Hex bolt 3/8"-16 x 3/4"	2	2	2	2	-	-	
14	193220	Drive weight 2.0 lb"	-	1	-	-	-	-	
15	193225	Drive weight 2.5 lb"	-	-	1	-	-	-	
16	193230	Drive weight 3.0 lb"	-	-	-	1	-	-	
17	330010	Hex bolt 1/4"-20 x 1"	-	-	-	-	-	2	
18	194606	Drive fixed weight	-	-	-	-	-	1	
19	336907	SCS screw 1/4"-20 x 3/4"	-	-	-	-	-	2	
20	194806	Adjustable weight	-	-	-	-	-	2	
21	347287	Retaining ring Internal #5000-287	2	2	2	2	2	2	
22	349118	Retaining ring External #5100-118	2	2	2	2	2	2	
23	380306	Bearing 6306	2	2	2	2	2	2	
24	200303	Shaft	1	1	1	1	1	1	
25	345803	Key 3/16" sq. X 1/2"	2	2	2	2	2	2	
26	142030	Housing C3/CEG (2 Mount holes)	1	1	1	1	1	1	
27	194306	Driven weight 6.0 lb"	-	-	-	-	1	-	
28	193315	Driven weight 1.5 lb"	1	-	-	-	-	-	
29	193320	Driven weight 2.0 lb"	-	1	-	-	-	-	
30	193325	Driven weight 2.5 lb"	-	-	1	-	-	-	
31	193330	Driven weight 3.0 lb"	-	-	-	1	-	-	
32	194706	Driven fixed weight	-	-	-	-	-	1	
33	110230	Cover	1	1	1	1	1	1	
34	330020	Hex bolt 1/4"-20 x 2"	4	4	4	4	4	4	

XI. 4AG Air Motor Parts Explosion & Parts List

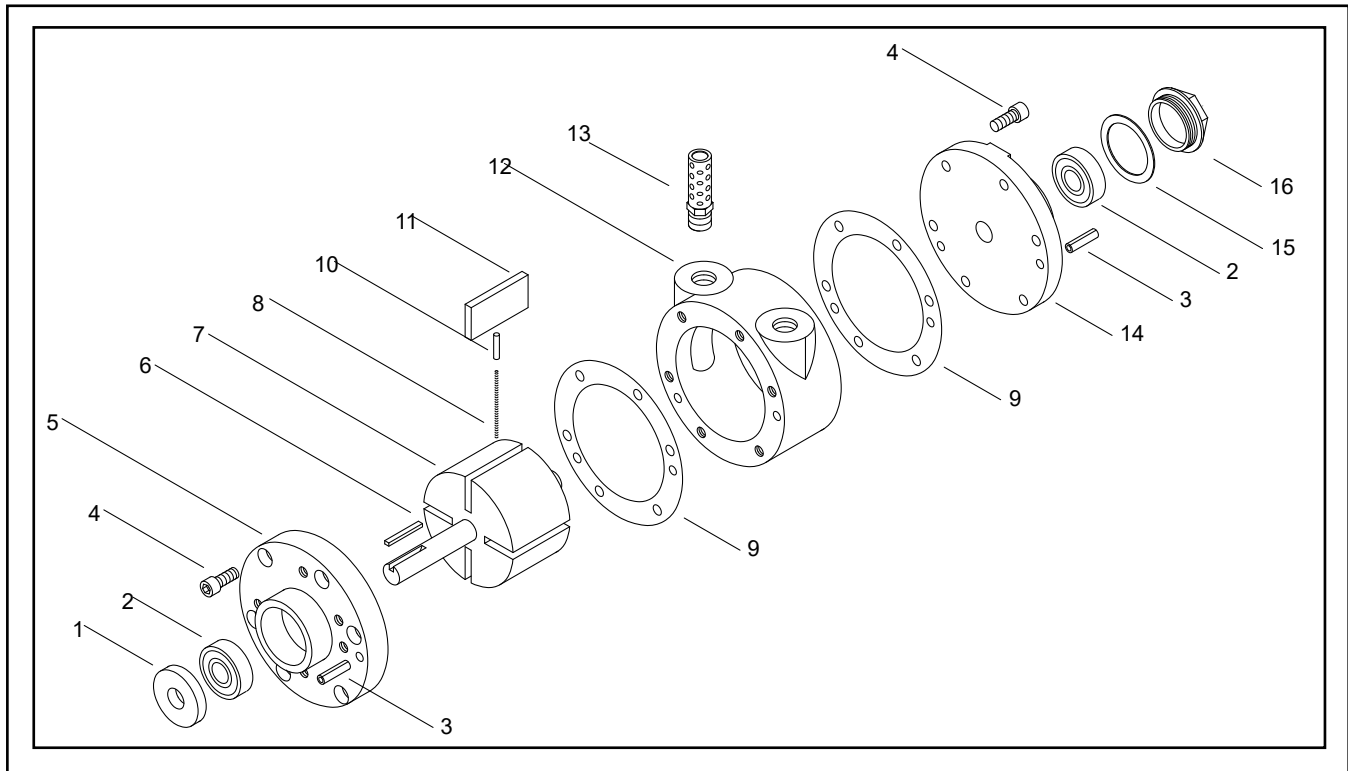

No.	Description	Part #		Qty
1	Shaft Seal	AA466B	(1)	1
2	Bearing, Drive & Dead	AA299J	(1)	2
3	Dowel Pin, 1/4" Diameter	NPN		4
4	SCS 1/4" Diameter	NPN		12
5	End Plate, Drive	AC665		1
6	Key - 1/8" sq. x .75" long	NPN		1
7	Rotor Assembly	AB617		1
8	Vane Spring	AM466	(1)	2
9	Body Gasket	BB330	(1)	2
10	Push Pin	AM467	(1)	4
11	Vane	AB876	(1)	4
12	Body	AM410		1
13	Muffler, 1/2"	270008		1
14	End Plate, Dead	AC728		1
15	End Cap, Gasket	AA46		1
16	End Cap, Dead	AM307D		1
NOTES:(1) Parts included in Repair Kit #240940				

XII. Assembly & Disassembly

Tools Required:

Torque wrench - 3/8" drive minimum 33 ft-lb capacity
7/16" combination wrench
1/2" combination wrench
9/16" combination wrench
2 ea 12" pry bars
1/8" hex key
3/16" hex key
1 press rod 3/4" diameter x 6" long
1 press tube 2 3/4" o.d. x 2 1/4 i.d. x 6" long
Retaining ring pliers to fit medium retaining rings, inside and outside
Thread locking adhesive

Procedure:



1. Remove the four screws from the back cover with a 7/16" wrench. Remove the back cover.

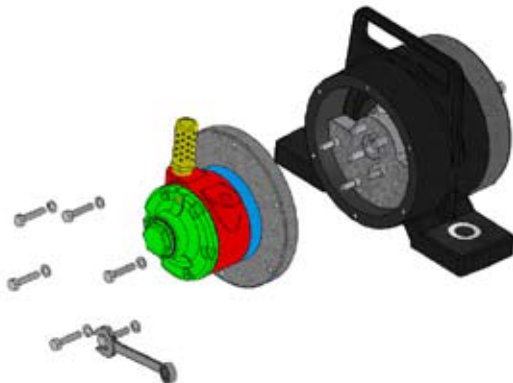

2. Remove the six 1/4" - 20 screws from the motor cover with the 7/16" wrench. Remove motor cover.

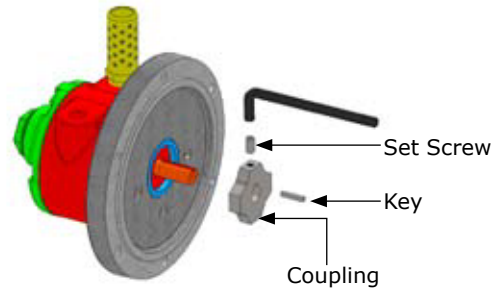

3. Remove the set screw from the coupling with a 1/8" hex key. Slide the coupling and key from the motor shaft.

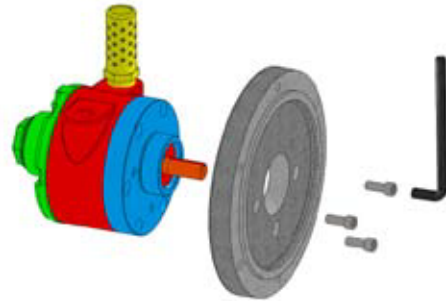

4. If motor repair is necessary remove the three motor screws that mount the motor to the motor cover with a 3/16" hex key.

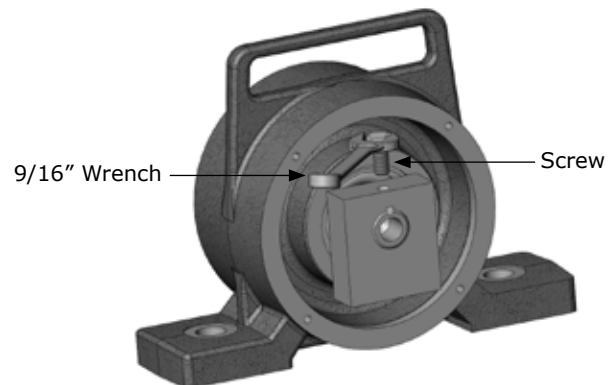

5. For models with fixed weights remove the screw from the driven weight (the weight without the drive pins) with a 9/16" wrench.

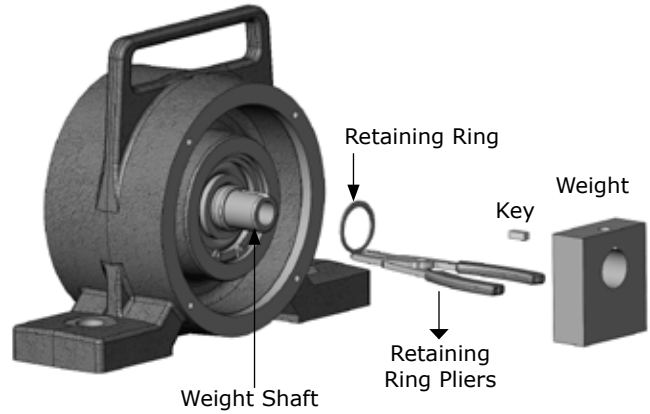
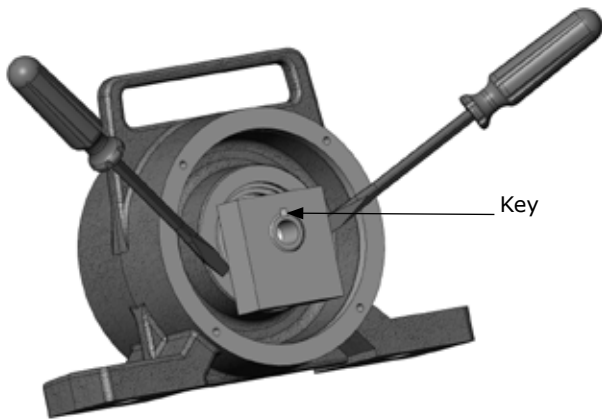

6. Pry the weight from the shaft as shown in the drawing. Repeat the procedure for the weight on the opposite side. Remove the keys from each end of the shaft.

8. Use external retaining ring pliers to remove the retaining ring from the weight shaft.

9. Repeat steps 5 - 7 to remove the drive weights from the motor side (opposite side) of the vibrator.

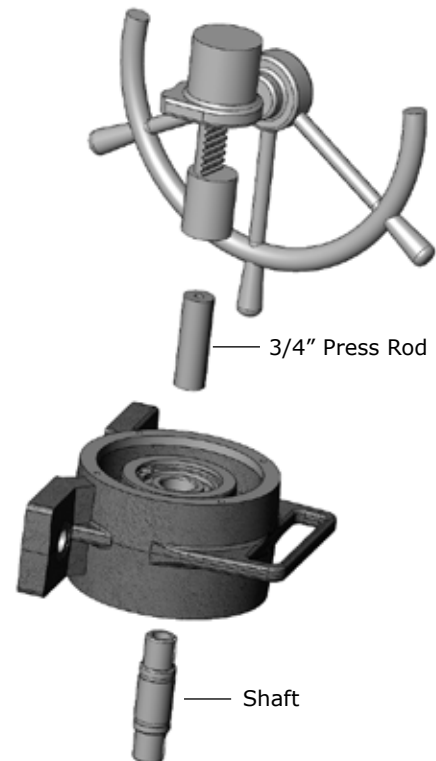
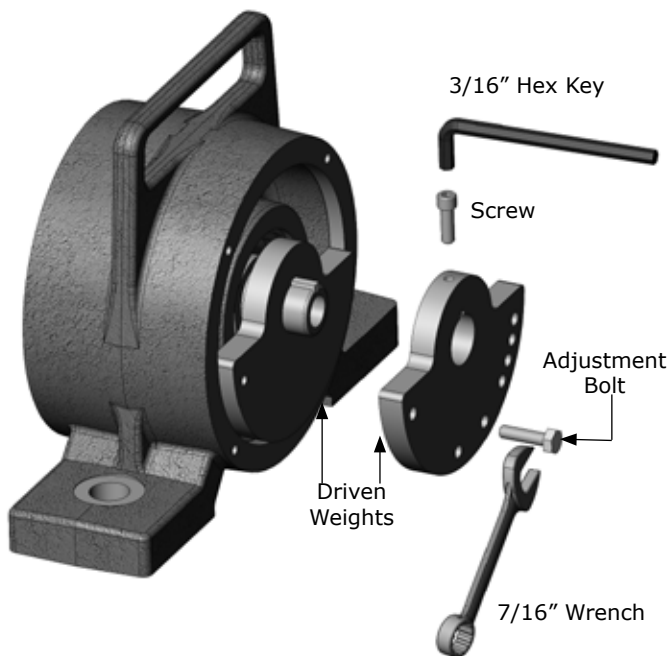

7. For models with adjustable weights remove the adjustment bolt locking the weights together with a 7/16" wrench. Note the screw location in the weight for proper replacement. Remove the screw from the top of the driven weight (no drive pins) with a 3/16" hex key. Pry the weights off the shaft.

10. Use a press and a 3/4" press rod to press the shaft through the bearings. Do not use a hammer as it will damage the shaft end and bearings (especially if they are going to be reused).

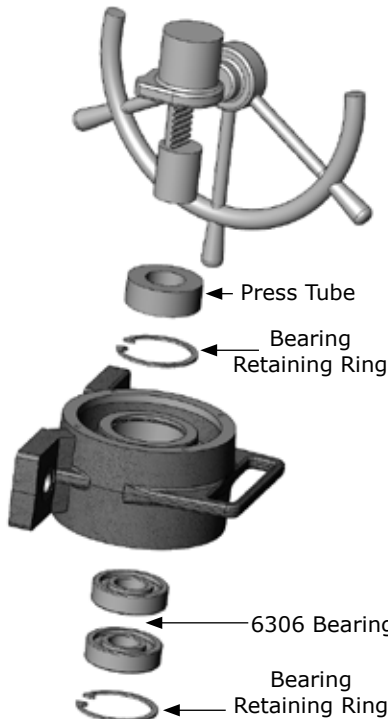

11. Remove the bearing retaining rings (internal) from the housing with the inside retaining ring pliers. Use the 2 3/4" press tube to force the bearings out of the housing bore. Do not press on any bearing surface except the outer race.

Reassembly

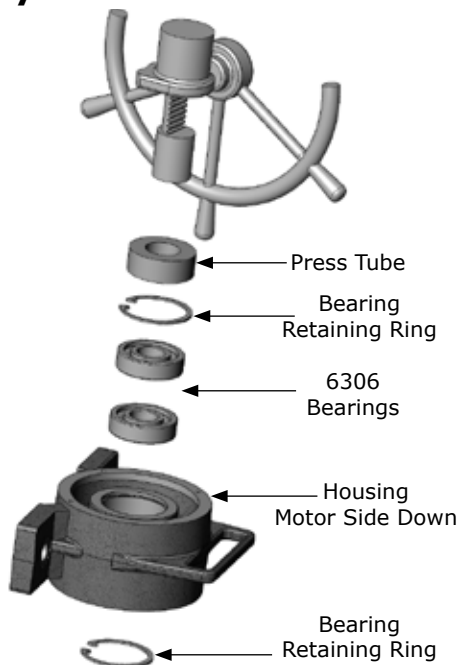

12. Install one of the bearing retaining rings into the housing bearing bore. Apply a light coat of oil on the outer race of the bearings. Use a 2 3/4" x 6" press tube to press the bearing into the bore until it contacts the inner face of the retaining ring. Press the remaining bearing into the bore until it contacts the first bearing. Install the remaining ring into the bearing bore.

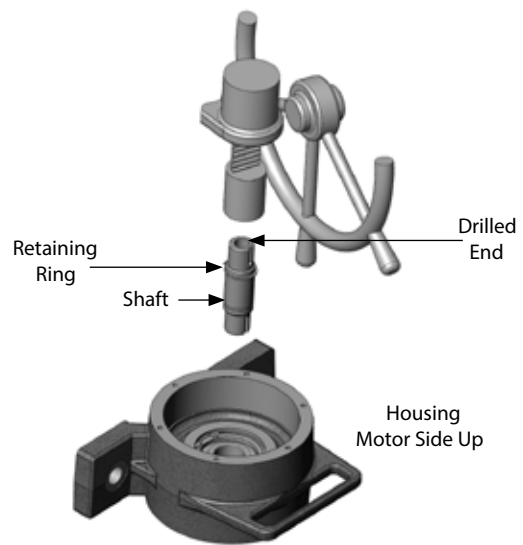

13. Turn the housing so that the motor side is facing up. Install a retaining ring closest to the drilled end on the shaft. Slide the shaft into the bearings (from motor side) until the retaining ring contacts the inner race of the bearing. This may require a light press. Do not hammer on the shaft to avoid damage to it and the bearings. When the shaft is in place, replace the retaining ring into the opposite side shaft groove.

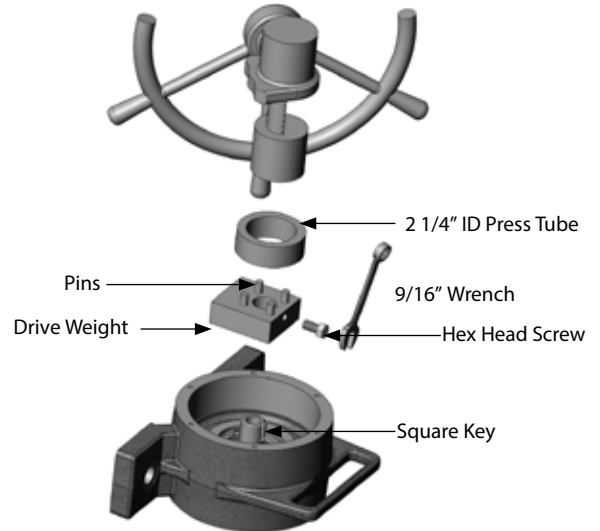

14. For models with fixed weights, install the 3/16" square key in shaft keyway. Align the keyway in the weights with the key in the shaft. Slide the drive weight (with pins up) onto the shaft until it seats against the shoulder stop. Support the shaft on the opposite side to prevent damage to bearings. This procedure may require a light press. Do not use a hammer as it will damage the bearings. Place a drop of thread adhesive on the 3/8" - 16 x 1 1/4" hex head screw. Install the set screw into the weight and torque to 33 ft-lb (45 N-M). Repeat procedure for the driven weight on opposite side of housing.

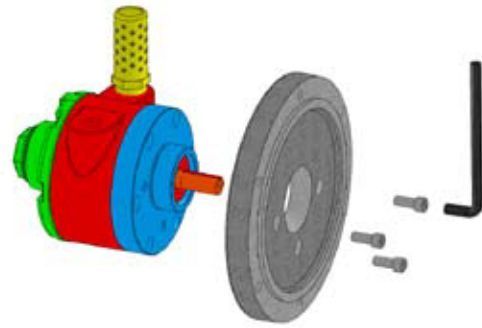
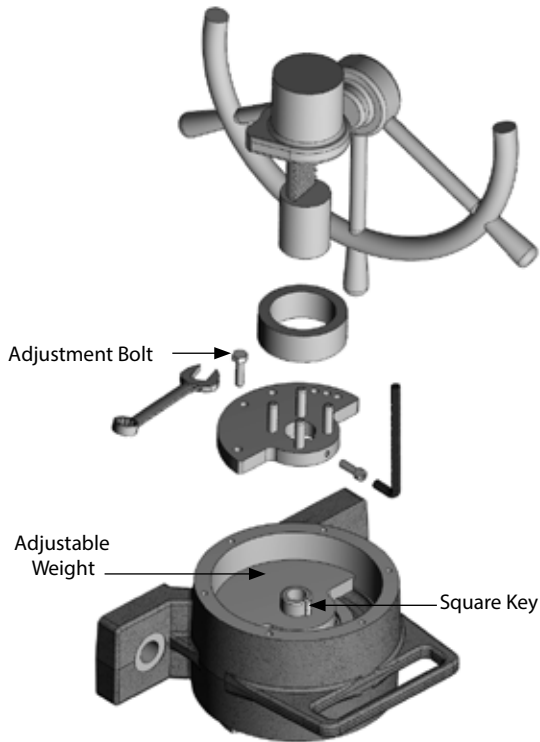

16. If removed, place the pneumatic motor on the motor cover. Place a drop of thread adhesive on the threads of the three 1/4-20 x 5/8" SCS Screws. Slide the screws into the cover from the inside and into the threaded holes in the motor. Tighten in stages in a crisscross pattern until tight. Aim for a bolt torque of approximately 12 ft-lb (24 N-M).

15. For models with adjustable weights, slide the adjustable weight (no pins) onto the shaft until it seats against the shoulder. Support the shaft on the opposite side to prevent damage to the bearings. Do not use a hammer as it will damage the bearings. Replace the square key into the shaft. Slide the drive weight over the shaft aligning the weight keyway with the key in the shaft. The weight will rest against the adjustable weight. Rotate the adjustable weight until the adjustment bolt hole is aligned with the correct hole in the adjustable weight.

NOTE: The adjustable weight is milled on both sides. The adjustment hole should be on the right on the motor side and on the left (when facing shaft) on the non-motor side. Also, milled faces on the weights should face each other on both sets of weights.

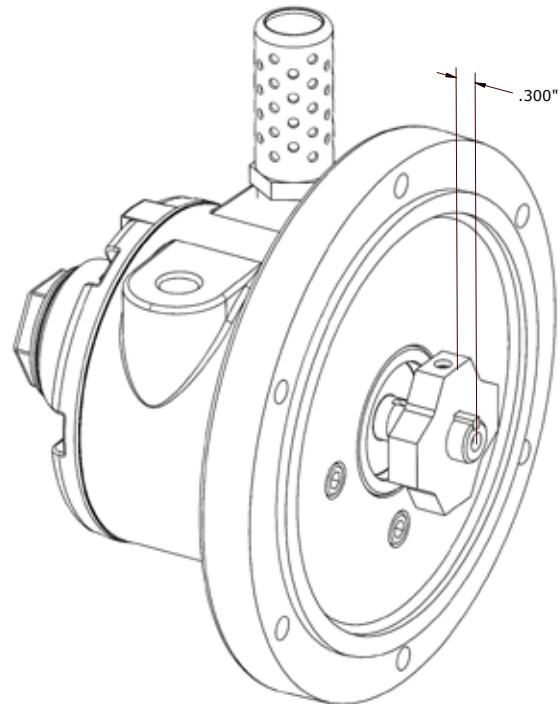

Place a drop of thread adhesive on the 3/8" - 16 hex bolt and install through the drive weight into the adjustable weight. Tighten securely. Place a drop of thread adhesive onto the thread of the 1/4" - 20 socket cap screw and install in screw hole at drive weight. Repeat procedure to install the driven weights on opposite side

17. Slide the coupling onto the motor shaft until the outer face of the coupling is flush with the end of the motor shaft. Push the 1/8" square key into the key slot formed by the coupling and shaft keyways. Continue sliding the coupling down the shaft until .300" of the motor shaft is protruding through the coupling.

NOTE: Do not place the key in the shaft keyway prior to installing coupling as the coupling will force the key into the motor seal upon installation causing the seal to leak.

When adequate backlash is attained, remove cover bolts and apply a drop of thread adhesive to the 1/4" - 20 coupling set screw and tighten securely against the key and motor shaft.

Reinstall the motor cover on the housing. Use a drop of thread adhesive on all six 1/4" -20 hex bolts and torque evenly in a crisscross pattern to 12 ft-lb each.

Reinstall back cover.

Note: If coupling wears out, often the pins in the drive weight will also be worn. The best remedy for this is to order a replacement drive weight (see page 19). This drive weight comes with the pins installed. Installing new pins in the weight is difficult and requires a hydraulic press capable of at least 10,000 pounds of force.

Aligning the cutouts on the coupling with the drive pins on the weight, slide the motor cover onto the housing. Install 3 bolts 120° apart through motor cover and into housing. Turn the weight on the opposite side of the housing to make sure weights and motor turn freely and are not binding at any point. As weight is swung back and forth, a slight "clicking" can be heard. This indicates proper slack or backlash between the coupling and the drive pins on the weight. If there is binding, remove motor cover and move the coupling back an additional .020" on the shaft and repeat trial fit.

XIII. Vibrator & Motor Performance Data

PNEUMATIC DESIGN SERIES VIBRATORS Performance Data											
VIBRATOR MODEL	UNBALANCE	PRESSURE	40 PSI (2.8 BAR)			60 PSI (4.1 BAR)			80 PSI (5.5 BAR)		
		START-UP	SPEED	FLOW	FORCE	SPEED	FLOW	FORCE	SPEED	FLOW	FORCE
	LB-IN	PSI	RPM	CFM	LBS	RPM	CFM	LBS	RPM	CFM	LBS
	KG-MM	BAR		LPM	KN		LPM	KN		LPM	KN
C3-1.5-4AC	1.5	8	4,400	41	820	5,150	55	1,130	5,650	74	1,360
	173	0.6		1,161	4		1,557	5		2,095	6
C3-2.0-4AC	2.0	8	4,310	40	1,050	4,980	54	1,410	5,500	73	1,720
	230	0.6		1,133	5		1,529	6		2,067	8
C3-2.5-4AC	2.5	8	4,220	39	1,260	4,820	53	1,650	5,350	72	2,030
	288	0.6		1,104	6		1,501	7		2,039	9
C3-3.0-4AC	3.0	8	4,130	38	1,450	4,650	52	1,840	5,200	71	2,300
	346	0.6		1,076	6		1,473	8		2,011	10
C3-4.0-4AC	4.0	10	4,050	37	1,860	4,540	51	2,340	5,170	70	3,040
	461	0.7		1,048	8		1,444	10		1,982	14
C3-5.0-4AC	5.0	13	3,980	36	2,250	4,440	51	2,800	5,130	70	3,740
	576	0.9		1,019	10		1,444	13		1,982	17
C3-6.0-4AC	6.0	18	3,900	35	2,590	4,330	50	3,220	5,100	69	4,430
	691	1.2		991	12		1,416	14		1,954	20

NOTE: With any rotary vibrator, the load on the bearings increases as the speed increases; therefore, increasing the speed by just 10% will cut the bearing life in half. Likewise, reducing the speed 10% will double the bearing life. The speed is controlled by the flow or volume of air (CFM) in relation to the pressure (PSI). The pressure of the motor will vary according to the rigidity of the vibrator mount and the type of material in the bin/hopper.

4AG PNEUMATIC MOTOR Performance Data						
PORT SIZE	MINIMUM HOSE SIZE	MAXIMUM CONTINUOUS OPERATION	MAXIMUM SPEED INTERMITTENT OPERATION	MAXIMUM PRESSURE	MAXIMUM FLOW	LUBRICATION REQUIRED
1/2"-14 NPT	1/2" I.D.	4,000 RPM	5,000 RPM	100 PSI (7 Bar)	100 CFM (47 LPS)	1 drop for every 50 CFM of air while unit is running

XIV. Troubleshooting Guide

PROBLEM	PROBABLE CAUSE	SOLUTION
Vibrator will not operate	Airline blocked	Locate obstruction and remove. Check for kinked airline. Check filter.
	Inadequate air supply	Increase regulator settings or reduce number of units in use at same time. Check capacity of compressor.
	Airline too small for hose length	Use larger airline.
	Contamination in vibrator motor	Disassemble and clean motor. Check filter element.
	Faulty valve or airline couplings	Clean, repair, or replace.
	Clogged filter	Clean or replace filter.
Vibrator operates slowly	Airline leaking or constricted	Repair airline, valves, or filter.
	Airline too small for distance used	Replace airline with larger size airline.
	Filter or muffler clogged	Clean, repair, or replace.
	Contaminants in vibrator	Disassemble and clean.
	Lubricant too thick in cold weather	Use a lighter weight lubricant.
Excessive Noise	Insufficient mount	Replace with stronger mounting apparatus.
	Damaged housing	Replace the housing.
	Lubricator clogged or empty	Check oil level and flow rate. Keep reservoir full.
	Muffler not used	Install muffler.
	Bearing failure (squealing sound)	Replace bearings.
	Vibrator is running too fast	Reduce speed by adjusting the PSI.