

**STEPHENS-ADAMSON**  
Conveyor Components

# CONVEYOR HOODS

## A-1 FULL STYLE

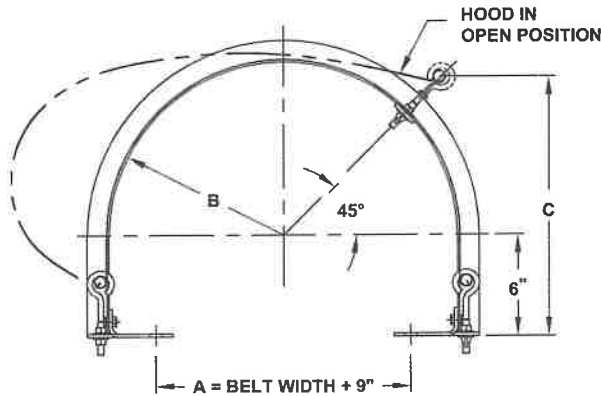

## 4'-0" LONG SECTIONS

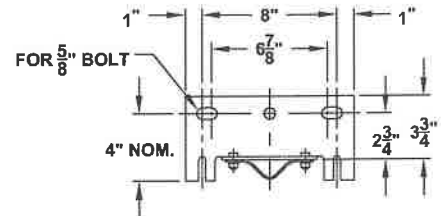
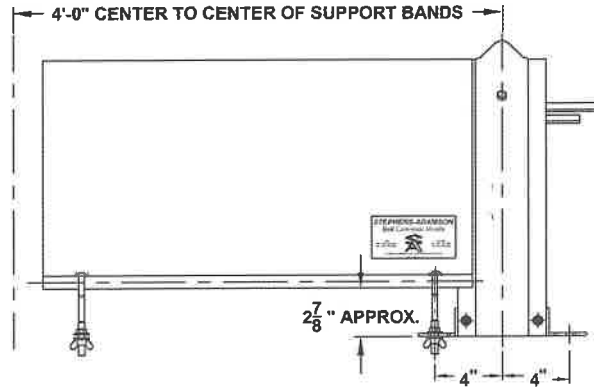

### A-1 FULL STYLE GALVANIZED HOODS

Belt Width	Part Number	Price	A	B	C	Wt., LBS
18	MP-HOD01-002-A	*	27	16-1/4	19-1/2	49
20	MP-HOD01-002-B	*	29	17-1/4	20-1/4	51
24	MP-HOD01-002-C	*	33	19-1/4	21-5/8	55
30	MP-HOD01-002-D	*	39	22-1/4	23-3/4	60
36	MP-HOD01-002-E	*	45	25-1/4	25-7/8	66
42	MP-HOD01-002-F	*	54	28-1/4	28	78
48	MP-HOD01-002-G	*	57	31-1/4	30-1/8	84
54	MP-HOD01-002-H	*	63	34-1/4	32-1/4	90
60	MP-HOD01-002-J	*	69	37-1/4	34-3/8	97
72	MP-HOD01-002-K	*	81	40-1/4	40-5/8	109

### EXTRA BAND KIT

A-1 FULL	
Part Number	Price
MP-HOD01-02-01	*
MP-HOD01-02-02	*
MP-HOD01-02-03	*
MP-HOD01-02-04	*
MP-HOD01-02-05	*
MP-HOD01-02-06	*
MP-HOD01-02-07	*
MP-HOD01-02-08	*
MP-HOD01-02-09	*
MP-HOD01-02-10	*

**NOTES:**

- ONE COMPLETE CONVEYOR HOOD SECTION CONSISTS OF ONE COVER, ONE BAND, TWO FOOT BRACKETS, ONE RETAINING BAR, BOLTS, NUTS, AND WASHERS.
- ONE EXTRA BAND KIT IS REQUIRED FOR EACH CONVEYOR. ONE BAND KIT CONSISTS OF ONE BAND, TWO FOOT BRACKETS, ONE RETAINING BAR, BOLTS, NUTS, AND WASHERS.
- CONTACT S-A FOR CUSTOM LENGTHS AVAILABLE UP TO 5'0" LONG.

**ALSO AVAILABLE IN ALUMINUM  
AND WITH SAFTEY CHAIN**