



MODEL AD

BIN AERATOR

END FLOW PROBLEMS **FOREVER!**

Model AD Aerators provide positive flow of dry, finely ground materials from any bin using the proven principle of aeration. Low pressure air is introduced into the product, restoring its natural ability to flow. In this way congestion, bridging and rat-holing are overcome without resorting to brute force. Almost all flow problems inherent to dry, fine materials are caused by compaction. When low pressure air is introduced to a finely ground material it will flow like water, uniformly and quickly.

Model AD Aerators are non-clogging and provide equal distribution and consumption of air. They feature simple and quick installation. Simply drill a 7/16" hole in bin wall insert, special tank nipple through hole and secure with lock nut.

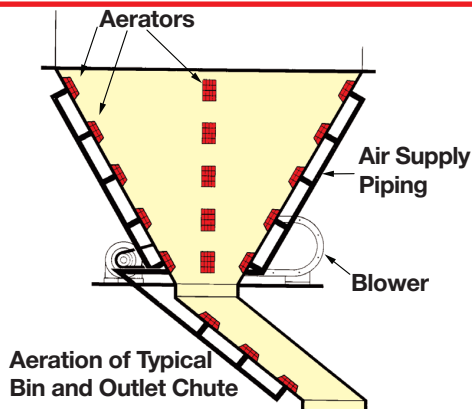

MATERIALS RESPONDING TO AERATION

Aeration gives the best results on materials with a 60 mesh size or smaller and with a 3% or less moisture content. Specific materials that respond well to aeration are as follows: Lime, Portland Cement, Carbon Black, Diatomaceous Earth, Flour, Soda Ash, Gypsum, Fly Ash, Pigments, Soap Powders, Bentonite, Bran Clay, Cereals, Fullers Earth, Detergents and many others. For questionable materials please contact our sales department.

ADVANTAGES OF AERATION

- Positive, uniform and easily controlled flow
- Eliminates Bridging and Rat-holing
- Quiet operation
- Low power requirements
- First in / first out flow
- Adapts to any bin configuration
- Low-Cost, Easy to Install, Maintenance Free

EXCLUSIVE

Heavy-Duty construction features stiffeners to prevent crushing of air compartment. These stiffeners eliminate the possibility of the Aerator being crushed by weight of material or by personnel stepping on it when cleaning the bin. The stiffeners do not obstruct the diffusion of air.

CUTAWAY VIEW

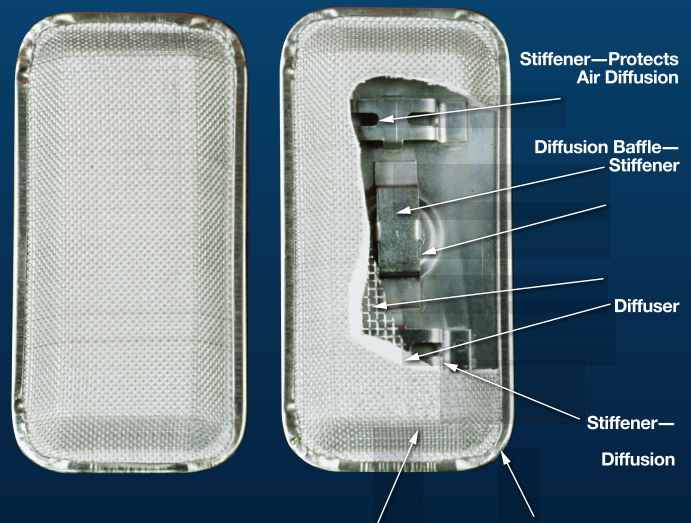

MODELS

MODEL	DESCRIPTION	SHPG. WT. LBS
AD-C	Zinc plated steel body with galvanized steel mesh and cotton diffuser. Brass nipple and lock nut. Nickel plated steel spacer washers and rubber gasket.	0.7
AD-F	Zinc plated steel body with galvanized steel mesh and fiberglass diffuser. Brass nipple and lock nut. Nickel plated steel spacer washers and rubber gasket. Typically used when temperatures exceed 200°F.	0.7
AD-SSC	Type 316 Stainless Steel body and mesh. Cotton diffuser. Nickel plated spacer washers, nipple and locknut. Rubber Gasket.	0.7
AD-SSF	Type 316 Stainless Steel body and mesh. Fiberglass diffuser. Nickel plated spacer washers, nipple and locknut. Rubber Gasket. Typically used when temperatures exceed 200°F.	0.7
AD-K	Optional mounting kit includes two positive sealing gaskets, adapter and clamp. Use with any of the aerators when mounting from outside the bin.	0.7

AERATOR SELECTION GUIDE:

For best results, locate lower aerators as close to the discharge outlet as possible. If material is held in the bin for long periods and/or compacted in transport, we recommend aerators be installed on 12" centers.

Aerators on 12" Centers

Length of Sloping Bin Wall	Number of Aerators Per Row
1'8" - 2'7"	2
2'8" - 3'7"	3
3'8" - 4'7"	4
4'8" - 5'7"	5
5'8" - 6'7"	6
6'8" - 7'7"	7
7'8" - 8'7"	8
8'8" - 9'7"	9
9'8" - 10'7"	10

Aerators on 15" Centers

Length of Sloping Bin Wall	Number of Aerators Per Row
1'11" - 3'1"	2
3'2" - 4'4"	3
4'5" - 5'7"	4
5'8" - 6'10"	5
6'11" - 8'1"	6
8'2" - 9'4"	7
9'5" - 10'7"	8
10'8" - 11'10"	9
11'11" - 13'1"	10

Generally four rows of aerators on 12" or 15" centers are recommended. On conical bins these rows are spaced equally. On pyramidal bins, rows are spaced equally on sloping sides or in valleys if material tends to hang up in these valleys.

AIR SUPPLY

Air supply must be clean and dry. We recommend positive displacement, low pressure blowers. Plant air can be used but the pressure must be reduced to 3 to 5 P.S.I. and a filter or moisture trap used on the low pressure side. The volume of air needed is a limiting factor on the use of plant air.

Air Consumption Guide Per Aerator

Manifold Piping Size Guide		Air Consumption Guide Per Aerator	
Piping Size	Number of Aerators in a Row	Air Pressure PSI	Cubic Feet Per Minute
3/4"	1-5	1	4.2
		2	5.7
		*3	6.5
1"	6-9	4	7.1
		5	7.6
1-1/4"	10-12	*Recommended for most applications	

MODEL AD AERATOR SPECIFICATIONS

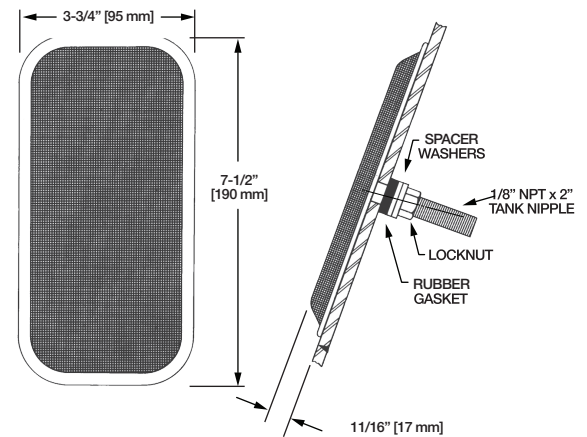

MODEL AD-K MOUNTING KIT (SOLD SEPARATELY)

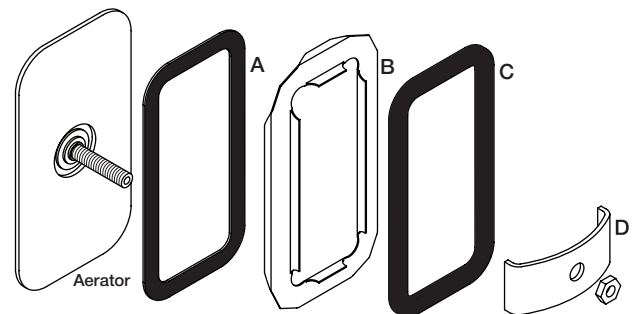

A. 1/16" gasket, adhesive both sides. B. Adaptor C. 3/16" gasket, adhesive one side. D. Spring Steel clamp.

The Model AD-K aerator mounting kit completely eliminates the need to enter the bin to install or service aerators. By cutting a 2-5/8" x 6-3/8" hole in the bin wall the mounting kit can be completely installed and serviced from outside the bin.

After the initial hole has been cut, the aerator is mounted on the adaptor assembly and inserted into the bin in less than two minutes. No holes to drill, no welding or tapping. The aerator is positively sealed and securely held in place in the bin. Removal is just as simple and quick.

Aerator kits are also adaptable for use on round bins. Installation is made with standard gaskets, and the 3/16" adhesive gasket ("C" above), on bins with a diameter of three feet or greater.

AERATOR KIT IN PLACE ON BIN

